



FILTEC ⁺ - FILTEC	PAGE
FILTEC⁺ Thread inserts presentation	1 - 6
FILTEC⁺ thread inserts product range	
FILTEC ⁺ metric M2 x 0,40 to M30 x 3,50	7 - 12
FILTEC ⁺ UNC 2-56 to 1"1/2-6	13 - 15
FILTEC ⁺ UNF 6-40 to 7/8-14	16 - 17
FILTEC ⁺ BSP-BSW-BSF	18 - 20
FILTEC⁺ Strip-feed thread inserts	21 - 22
FILTEC⁺ NOVADRILL Drills	
Metric drills M2 x 0,40 to M42 x 4,50	23
UNC-UNF drills 2-56 to 1"3/8-12 - BSP-BSW-BSF	24
FILTEC⁺ Taps	
Presentation and technical information	25
Metric taps M2 x 0,40 to M42 x 4,50	26
UNC-UNF taps 2-56 au 1"1/2-12	27
BSP-BSW-BSF taps	28
FILTEC⁺ Control Plug gauges	
Presentation and technical information	29
Metric / UNC-UNF / BSP-BSW-BSF plug gauges	30
FILTEC⁺ Inserting tools "single spindle"	
Presentation and metric / UNC-UNF inserting tools	31
ZT FILTEC⁺ Pneumatic tools	
Presentation and technical information	32
Metric / UNC-UNF pneumatic tools	33
FILTEC⁺ Break-off tool / extractors	
Presentation and technical information	34
Metric / UNC-UNF break-off tools – Metric automatic break-off tools	35 - 36
Metric / UNC-UNF / BSP-BSW-BSF extractors	37
FILTEC⁺ Monokits and blisters tool kits	
Presentation and technical information	38
Metric / UNC-UNF Blisters and Monokits	39
Metric / UNC-UNF Monokit assortment kits	40
FILTEC DIN 8140 Thread inserts product range	
FILTEC metric M2 x 0,40 to M16 x 2,00	41 - 42
Metric inserting tools M2 x 0,40 to M42 x 4,50	43
Metric repair tool kit M2 x 0,40 to M16 x 2,00	44
Metric assortment kit	45

Thread inserts



PRINCIPLE

FILTEC⁺ thread insert is used to reinforce or repair all types of tappings and enables safe and highly resistant screw fitting. Particularly adapted for soft materials, FILTEC⁺ thread insert presents a high resistance to thermal, corrosive and mechanical strain. Made of stainless materials, the FILTEC⁺ thread insert consists in a diamond-section rolled wire and is ideal for industrial applications. It includes a tail for easy installation, which can be broken after insertion to let the screw go through.



USES

Reinforcing original manufacturer tappings:

FILTEC⁺ thread insert can be used to reinforce initial manufacturer tappings in soft materials (aluminium, magnesium) or to ensure a highly resistant tapping. It is used in different areas such as: railway sector, mechanics, armament, electronics, car industry, aerospace sector etc.

Repairing worn or damaged tappings:

FILTEC⁺ thread insert enables users to easily bring worn or damaged tappings back to their original size. This reconditioning ensures a better reliability and a longer durability comparing to the initial tapping.

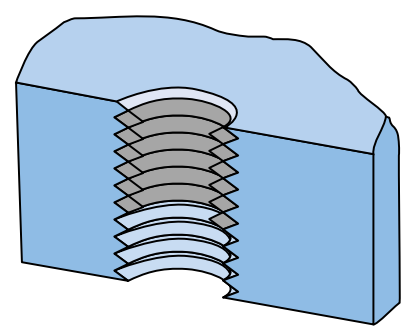
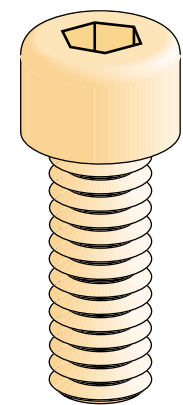



TECHNICAL SPECIFICATIONS

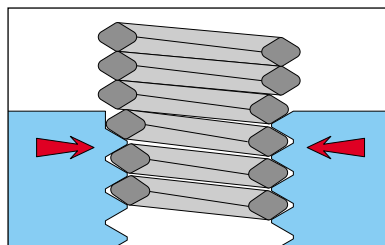

Strong resistance

Mechanical specifications

- As its original diameter is larger than the one of the tapping which receives it, it is impossible to unscrew.
- The advantages of this product are :
 - an increased resistance.
 - a reduced weight and size with a smaller screw dimension and less anchoring points

Material

- Made of stainless steel X10 Cr Ni 18-8.
- Possible coatings: dried lubrication (varnish of sliding), zinc plating, silver plating.
- Other possible materials upon request such as bronze, inconel, 316L...

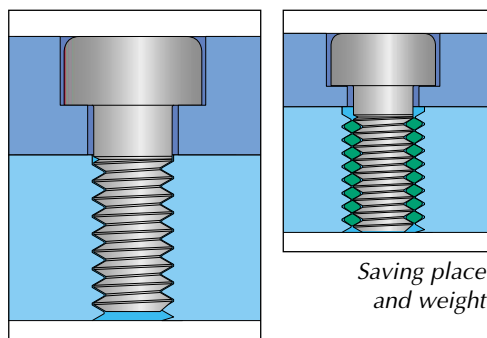

Saving place and weight

Resistance to deterioration / wear

- Diamond-sectioned stainless steel rolled wire with a 1400 N/mm² tensile strength.
- Surface roughness limits friction and provides tapping with a better resistance to wear.

Resistance to corrosive environments and chemical strain

- Made of stainless steel, it is resistant to chemical or atmospheric corrosion. Thus, in many cases it avoids using complex and expensive treatments on the surface of the parts.
- FILTEC⁺ thread insert in stainless steel is resistant to high temperature up to 425° C maximum for a short period of time and up to 325 ° C maximum without interruption.

This temperature can reach 750 ° C for inconel thread inserts.

Strain distribution

Thanks to its elasticity, strains are distributed along the whole thread length. By smoothing out unevenness in pitch and angle in thread walls, FILTEC⁺ can be considered as a joint.

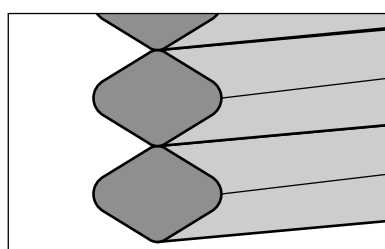

Wire with diamond shape

Thread

- Metric ISO according to NF E 03 051 6 H
- UNC (Unified National Coarse) / UNJC
- UNF (Unified National Fine) / UNJF
- GAZ (ISO 03-005) / BSP (British Standard Pipe)
- BSW (British Standard Withworth)
- BSF (British Standard Fine)



FILTEC⁺ STANDARD RANGE

FILTEC⁺

With its optimised design, this new generation of thread inserts presents a simplified installation.

Applications

- FILTEC⁺ product range is the most commonly used product range of thread inserts for repairing damaged tapping and reinforcing original ones in the industry. The FILTEC⁺ range is wide in order to meet our customers specific needs.

Product specifications

- FILTEC⁺ inserting tools are easier to handle than the previous ones as they do not have a necked nose. You will still be able to use your inserting tool with a necked nose.

Green FILTEC⁺ : green colour version

Green FILTEC⁺ thread insert can be delivered upon request. Its green colour makes the thread visible to the eye when it is inserted in aluminium tappings.



Green colour in option

LOCKFIL⁺ : self-locking version

LOCKFIL⁺ thread insert presents one or more deformed polygon shaped turns which exert pressure on the thread walls thus it makes it impossible to unscrew.

Applications

- LOCKFIL⁺ thread insert is particularly well adapted for difficult situations (vibrations, shocks, etc.)
- This blocking system is efficient and replaces advantageously the other systems (locking washer, stop bolts, castellated nuts, locking nuts, etc)
- Compared with other systems, for an equivalent tightening torque, LOCKFIL⁺ thread insert presents a higher space / torque efficiency ratio.

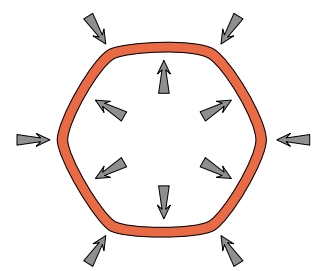

Blocking system of the LOCKFIL⁺

Product specifications

- LOCKFIL⁺ thread insert presents the same mechanical specifications as the FILTEC⁺ one.
- Installation is similar to classical thread inserts and requires the same inserting tools.
- LOCKFIL⁺ range of products complies with the ISO 2320 norm in terms of braking and tightening torque (see table below).
- The classical LOCKFIL⁺ is in red colour. A colourless version is available upon request.



LOCKFIL/LOCKFIL ⁺ : ISO 2320 tightening torque values (in Nm) valid for fine or normal pitch for class 8									
Threading	M4	M5	M6	M8	M10	M12	M14	M16	M18
Tightening torque	2,5	5	8,6	21	42	76	121	189	261
1st max. screwing	0,9	1,6	3	6	10,5	15,5	24	32	42
1st min. unscrewing	0,18	0,29	0,45	0,85	1,5	2,3	3,3	4,5	6
5th min. unscrewing	0,12	0,2	0,3	0,6	1	1,6	2,3	3	4,2



FILTEC DIN 8140 SPECIFIC RANGE

FILTEC® DIN 8140

Specially designed for the aeronautics and automotive industries, FILTEC thread inserts have been used for decades in the different sectors of the industry (mechanics, electronics, shipbuilding,...).

This range of products is the only one to comply with the DIN 8140. The use of an inserting tool with a necked nose is compulsory for FILTEC thread inserts.

LOCKFIL® DIN 8140 : self-locking version

LOCKFIL thread insert presents the same technical specifications as the LOCKFIL + one. However the LOCKFIL thread insert is the only one to comply with the DIN 8140. The use of an inserting tool with a necked nose is compulsory for LOCKFIL products.

QUALITY

ISO 9001 - 2000 version

Our manufacturing and distribution processes are ISO 9001 certified.

TRACEABILITY

The batch number mentioned on all the packages enables us to find not only the specifications of the material used for the product but also the production report of the items produced. To ensure a complete traceability, the batch number is visible on both the delivery notes and the invoices.

CERTIFICATES

Upon special request and for a fee, we can deliver three types of certificates :

Certificate of conformity in compliance with **NF-L-00-015**
Conformity declaration of goods ordered

Materials certificate in compliance with **NF EN 10204**
Chemical analysis and mechanical specifications

Control report

Reports of the measures taken on initial samples and during manufacturing process



GENERAL ASSEMBLY INSTRUCTIONS

Applications

FILTEC+ thread inserts are easily installed using a specific tool.

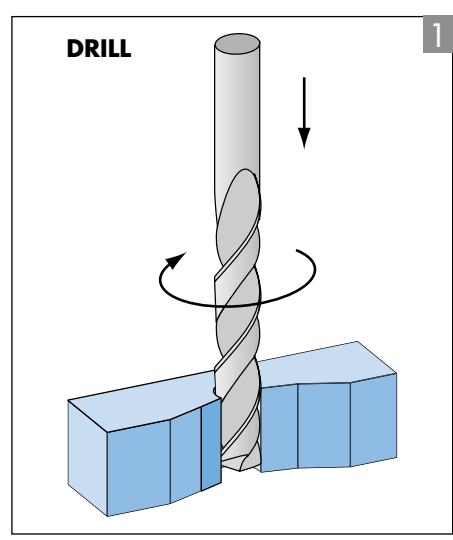

Drilling :
Eliminate traces of initial tapping by drilling. Be careful to follow recommended drill diameters.

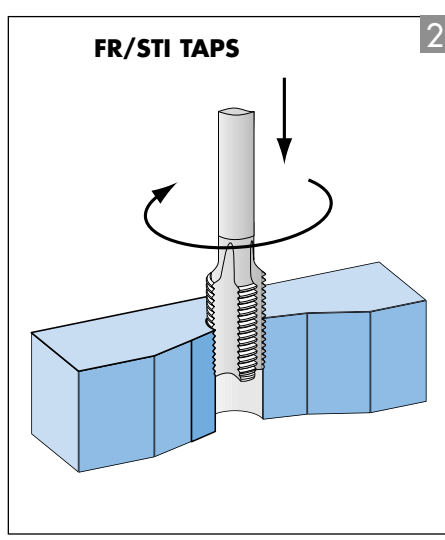

Tapping :
Use FR/STI screw tap corresponding to the thread insert used (use lubricant, oil or grease for this operation)

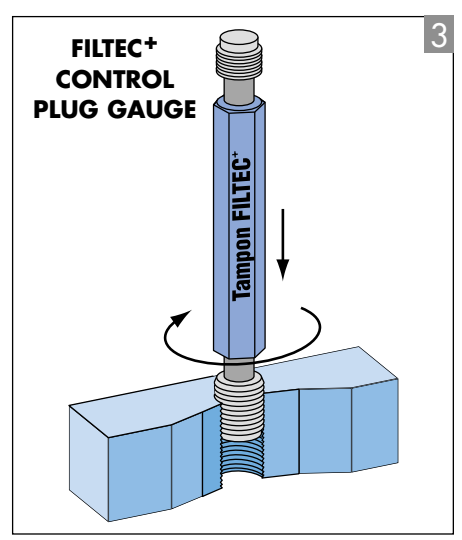

Controlling the tapping :
With its specific insertion features, the over-dimensioned FILTEC+ control plug gauge enables users to check the tapping conformity (optional operation)

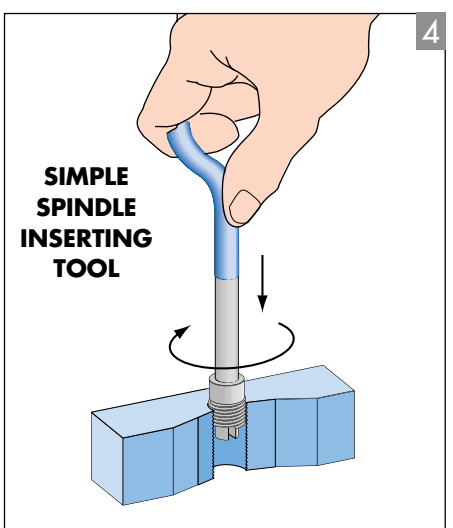

Installation of thread insert :
Insert the tool in the drilled hole. Lower the thread insert into the tapping by turning the tool but without applying pressure (the thread should be positioned between 0.25 and 0.75 of pitch below the tapping opening). A pneumatic insertion tool may also be used for larger series.

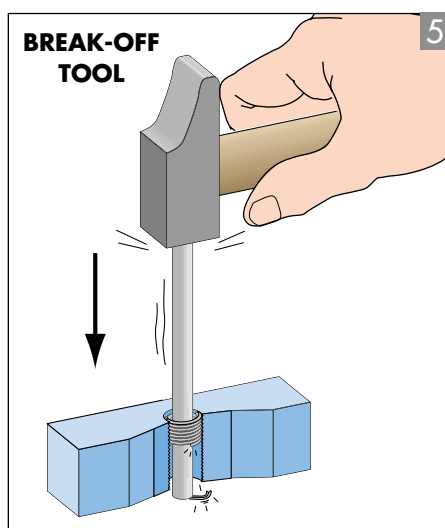

Break-off tool:
Break the tail off using the break-off tool in order to use the whole length of the tapping.

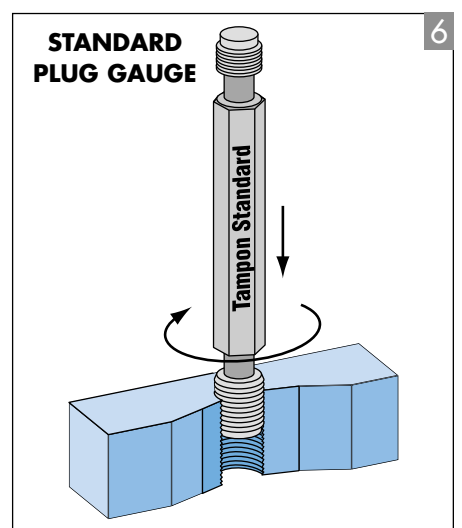

Final check :
The STANDARD plug gauge enables users to check the conformity of the tapping obtained.



DIMENSION SHEETS

Ø and pitch	x d	D : base tapping length	CODE 127 : Filtec+ 125 : Green Filtec+ 104 : Lockfil+	H : nb. of turns at the initial state Tel. -0,25	G : Ø initial state min - max	A : Drilling		Tapping	
						Ø drill	Tolerance min max	B : Ø ext. min	C : Ø outer
M 10 x 1,25 1	1 d	10,00	127 10 02 10 00	6,15	11,75 12,00 5	10,40 6	10,271 + 0,212	11,624 7	10,812 + 0,099
	1,5 d	15,00	127 10 02 15 00	10,00					
	2 d	20,00	127 10 02 20 00	13,50					
	2,5 d	25,00	127 10 02 25 00	17,00					
	3 d	30,00	127 10 02 30 00	20,70					

1 **FILTEC⁺ M10 x 1,25** : Refers to a stainless steel metric insert for M10 thread with 1,25 pitch.

2 **Multiple of the diameter**

3 **Base length**

Corresponds to the minimum tapping length for thread insert fitting.

4 **Codes**

The first three figures of the code correspond to the thread insert type :

127 : FILTEC⁺

125 : Green FILTEC⁺

104 : LOCKFIL⁺

5 **Initial FILTEC⁺ dimension**

Initial thread insert diameter (G) is larger than dimension of tapping it is to be fitted in. It is therefore impossible to unscrew.

By counting the number of turns of a thread insert in initial state (H), it is possible to find back its reference. The tolerance is of +/- 0.25.

6 **Drilling**

Ø of drill to be used with selected thread insert as well as accepted tolerance.

7 **Tapping**

Tolerance measures for tapping.

SELECTION CRITERIA

Usable length of the FILTEC⁺ thread insert

The length is calculated as follow depending on the type of hole that will receive the thread insert :

Open ended hole :

Maximum usable length **E** corresponds to the base length of tapping **D** minus 0,75 x pitch : **E = D - 0,75 x pitch**

Example: for a metric thread insert M8 x 125 with a length of 2,5 d :

$$E = 20,00 - 0,75 \times 1,25 = 19,06$$

Blind hole :

Usable length without breaking off the tail **F** corresponds to the base tapping length **D** minus 1,50 x pitch : **F = D - 1,5 x pitch**

Example: for a metric thread insert M8 x 125 with a length of 2,5d :

$$F = 20,00 - 1,50 \times 1,25 = 18,12$$

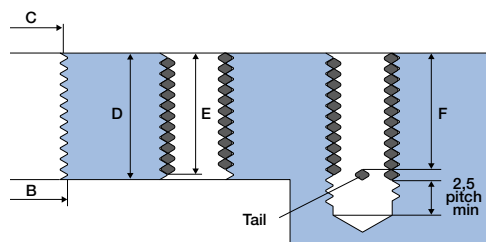

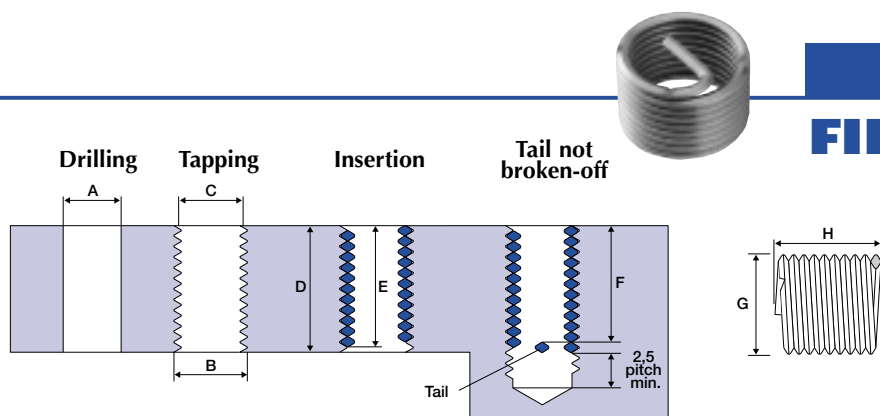

METRIC

Ø x pitch	x d	D : base tapping length	CODE 127 : Filtec+ 125 : Green Filtec+ 104 : Lockfil+	H : nb. of turns at the initial state Tolerance -0,25	G : Ø initial state min - max	A : Drilling		Tapping	
						Ø drill	Tolerance min max	B : Ø ext. min	C : Ø outer
M 2 x 0,40	1 d	2,00	127 02 40 02 00	2,90	2,60 2,75	2,10	2,090 + 0,090	2,520	2,260 + 0,053
	1,5 d	3,00	127 02 40 03 00	4,90					
	2 d	4,00	127 02 40 04 00	6,90					
	2,5 d	5,00	127 02 40 05 00	8,90					
	3 d	6,00	127 02 40 06 00	10,90					
M 2,5 x 0,45	1 d	2,50	127 02 45 25 00	3,60	3,15 3,30	2,60	2,597 + 0,100	3,084	2,792 + 0,055
	1,25 d	3,12	127 02 45 31 20	4,75					
	1,5 d	3,75	127 02 45 37 50	6,00					
	2 d	5,00	127 02 45 50 00	8,20					
	2,5 d	6,25	127 02 45 62 50	10,60					
M 3 x 0,50	1 d	3,00	127 03 50 03 00	3,95	3,70 3,90	3,20	3,108 + 0,112	3,650	3,325 + 0,059
	1,25 d	3,75	127 03 50 03 70	4,95					
	1,5 d	4,50	127 03 50 04 50	6,35					
	2 d	6,00	127 03 50 06 00	8,80					
	2,5 d	7,50	127 03 50 07 50	11,25					
M 3,5 x 0,60	1 d	3,50	127 04 60 35 00	3,90	4,35 4,45	3,70	3,630 + 0,125	4,280	3,890 + 0,069
	1,5 d	5,25	127 04 60 52 50	6,60					
	2 d	7,00	127 04 60 70 00	9,15					
	2,5 d	8,75	127 04 60 87 50	11,80					
	3 d	10,50	127 04 60 90 50	14,00					
M 4 x 0,70	1 d	4,00	127 04 70 04 00	3,80	5,00 5,15	4,20	4,152 + 0,140	4,910	4,455 + 0,074
	1,25 d	5,00	127 04 70 05 00	5,05					
	1,5 d	6,00	127 04 70 06 00	6,25					
	2 d	8,00	127 04 70 08 00	8,65					
	2,5 d	10,00	127 04 70 10 00	11,20					
M 5 x 0,80	1 d	5,00	127 05 80 05 00	4,45	6,10 6,30	5,20	5,174 + 0,160	6,040	5,520 + 0,077
	1,25 d	6,25	127 05 80 06 20	5,70					
	1,5 d	7,50	127 05 80 07 50	7,15					
	2 d	10,00	127 05 80 10 00	10,10					
	2,5 d	12,50	127 05 80 12 50	12,80					
M 6 x 1,00	1 d	6,00	127 06 01 06 00	4,30	7,40 7,65	6,30	6,217 + 0,190	7,300	6,650 + 0,092
	1,25 d	7,50	127 06 01 07 50	5,55					
	1,5 d	9,00	127 06 01 09 00	7,10					
	2 d	12,00	127 06 01 12 00	9,85					
	2,5 d	15,00	127 06 01 15 00	12,60					
	3 d	18,00	127 06 01 18 00	15,00					

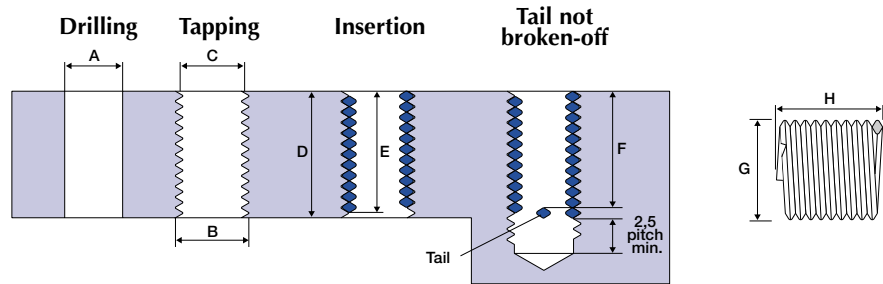
FILTEC[®]+

METRIC

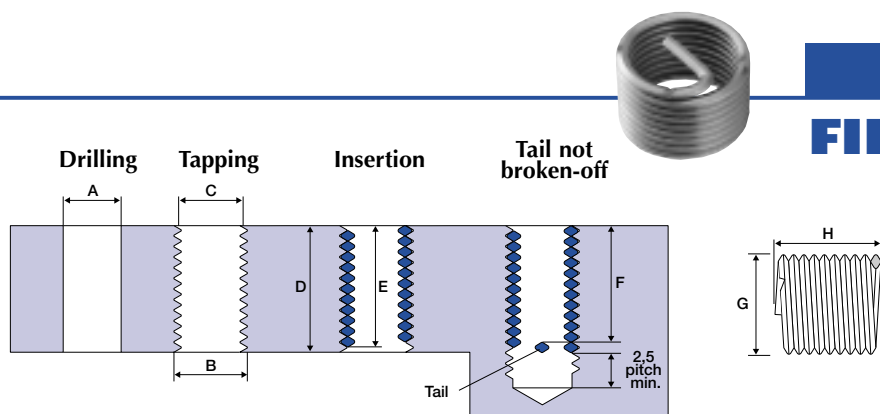
Ø x pitch	x d	D : base tapping length	CODE 127 : Filtec ⁺ 125 : Green Filtec ⁺ 104 : Lockfil ⁺	H : nb. of turns at the initial state Tolerance -0,25	G : Ø initial state min - max	A : Drilling		Tapping	
						Ø drill	Tolerance min max	B : Ø ext. min	C : Ø outer
M 7 x 1,00	1 d	7,00	127 07 01 07 00	5,45	8,40 8,65	7,30	7,217 + 0,190	8,300	7,650 + 0,092
	1,5 d	10,50	127 07 01 10 50	8,45					
	2 d	14,00	127 07 01 14 00	11,40					
	2,5 d	17,50	127 07 01 17 50	14,75					
	3 d	21,00	127 07 01 21 00	17,90					
M 8 x 1,00	1 d	8,00	127 08 01 08 00	6,30	9,45 9,75	8,30	8,217 + 0,190	9,300	8,650 + 0,092
	1,5 d	12,00	127 08 01 12 00	9,80					
	2 d	16,00	127 08 01 16 00	13,30					
	2,5 d	20,00	127 08 01 20 00	17,00					
	3 d	24,00	127 08 01 24 00	20,50					
M 8 x 1,25	1 d	8,00	127 08 02 08 00	4,80	9,70 9,90	8,40	8,271 + 0,212	9,624	8,812 + 0,099
	1,25 d	10,00	127 08 02 10 00	6,10					
	1,5 d	12,00	127 08 02 12 00	7,50					
	2 d	16,00	127 08 02 16 00	10,75					
	2,5 d	20,00	127 08 02 20 00	13,70					
M 9 x 1,25	1 d	9,00	127 09 02 09 00	5,40	10,70 10,90	9,40	9,271 + 0,212	10,624	9,812 + 0,099
	1,5 d	13,50	127 09 02 13 50	8,70					
	2 d	18,00	127 09 02 18 00	12,10					
	2,5 d	22,50	127 09 02 22 50	15,50					
	3 d	27,00	127 09 02 27 00	18,35					
M 10 x 1,00	1 d	10,00	127 10 01 10 00	7,90	11,60 11,90	10,30	10,217 + 0,190	11,300	10,650 + 0,092
	1,5 d	15,00	127 10 01 15 00	12,60					
	2 d	20,00	127 10 01 20 00	17,00					
	2,5 d	25,00	127 10 01 25 00	21,55					
	3 d	30,00	127 10 01 30 00	26,05					
M 10 x 1,25	1 d	10,00	127 10 02 10 00	6,15	11,75 12,00	10,40	10,271 + 0,212	11,624	10,812 + 0,099
	1,5 d	15,00	127 10 02 15 00	10,00					
	2 d	20,00	127 10 02 20 00	13,50					
	2,5 d	25,00	127 10 02 25 00	17,00					
	3 d	30,00	127 10 02 30 00	20,70					
M 10 x 1,50	1 d	10,00	127 10 03 10 00	5,00	12,05 12,35	10,50	10,324 + 0,236	11,948	10,974 + 0,115
	1,25 d	12,50	127 10 03 12 50	6,50					
	1,5 d	15,00	127 10 03 15 00	8,10					
	2 d	20,00	127 10 03 20 00	11,25					
	2,5 d	25,00	127 10 03 25 00	14,25					
	3 d	30,00	127 10 03 30 00	17,25					



METRIC

Ø x pitch	x d	D : base tapping length	CODE 127 : Filtec+ 125 : Filtec+vert 104 : Lockfil+	H : nb. of turns at the initial state Tolerance -0,25	G : Ø initial state min - max	A : Drilling		Tapping	
						Ø drill	Tolerance min max	B : Ø ext. min	C : Ø outer
M 11 x 1,50	1 d	11,00	127 11 03 11 00	5,60	13,05 13,35	11,50	11,324 + 0,236	12,948	11,974 + 0,115
	1,5 d	16,50	127 11 03 16 50	9,00					
	2 d	22,00	127 11 03 22 00	12,35					
	2,5 d	27,50	127 11 03 27 50	15,75					
	3 d	33,00	127 11 03 33 00	18,95					
M 12 x 1,00	1 d	12,00	127 12 01 12 00	9,75	13,70 14,10	12,30	12,217 + 0,190	13,300	12,650 + 0,100
	1,5 d	18,00	127 12 01 18 00	15,20					
	2 d	24,00	127 12 01 24 00	20,50					
	2,5 d	30,00	127 12 01 30 00	25,95					
	3 d	36,00	127 12 01 36 00	31,30					
M 12 x 1,25	1 d	12,00	127 12 02 12 00	7,75	13,75 14,05	12,40	12,271 + 0,212	13,624	12,812 + 0,114
	1,5 d	18,00	127 12 02 18 00	12,15					
	2 d	24,00	127 12 02 24 00	16,65					
	2,5 d	30,00	127 12 02 30 00	21,15					
	3 d	36,00	127 12 02 36 00	25,65					
M 12 x 1,50	1 d	12,00	127 12 03 12 00	6,30	14,10 14,40	12,50	12,324 + 0,236	13,948	12,974 + 0,125
	1,5 d	18,00	127 12 03 18 00	10,00					
	2 d	24,00	127 12 03 24 00	13,80					
	2,5 d	30,00	127 12 03 30 00	16,00					
	3 d	36,00	127 12 03 36 00	21,25					
M 12 x 1,75	0,75 d	9,00	127 12 04 09 00	3,70	14,35 14,60	12,50	12,379 + 0,265	14,274	13,137 + 0,134
	1 d	12,00	127 12 04 12 00	5,20					
	1,25 d	15,00	127 12 04 15 00	6,90					
	1,5 d	18,00	127 12 04 18 00	8,40					
	2 d	24,00	127 12 04 24 00	11,75					
	2,5 d	30,00	127 12 04 30 00	14,75					
	3 d	36,00	127 12 04 36 00	18,05					
M 14 x 1,50	0,75 d	10,50	127 14 03 10 50	5,40	16,25 16,65	14,50	14,324 + 0,236	15,948	14,974 + 0,125
	1 d	14,00	127 14 03 14 00	7,50					
	1,5 d	21,00	127 14 03 21 00	11,85					
	2 d	28,00	127 14 03 28 00	16,15					
	2,5 d	35,00	127 14 03 35 00	20,10					
	3 d	42,00	127 14 03 42 00	24,55					
M 14 x 2,00	0,75 d	10,50	127 14 05 10 50	4,00	16,80 17,15	14,50	14,433 + 0,300	16,598	15,299 + 0,145
	1 d	14,00	127 14 05 14 00	5,60					
	1,25 d	17,50	127 14 05 17 50	7,20					
	1,5 d	21,00	127 14 05 21 00	8,80					
	2 d	28,00	127 14 05 28 00	12,00					
	2,5 d	35,00	127 14 05 35 00	15,20					
	3 d	42,00	127 14 05 42 00	18,40					

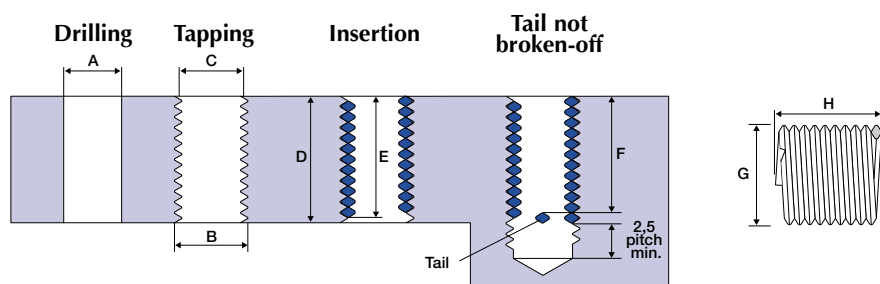
FILTEC[®]+

METRIC

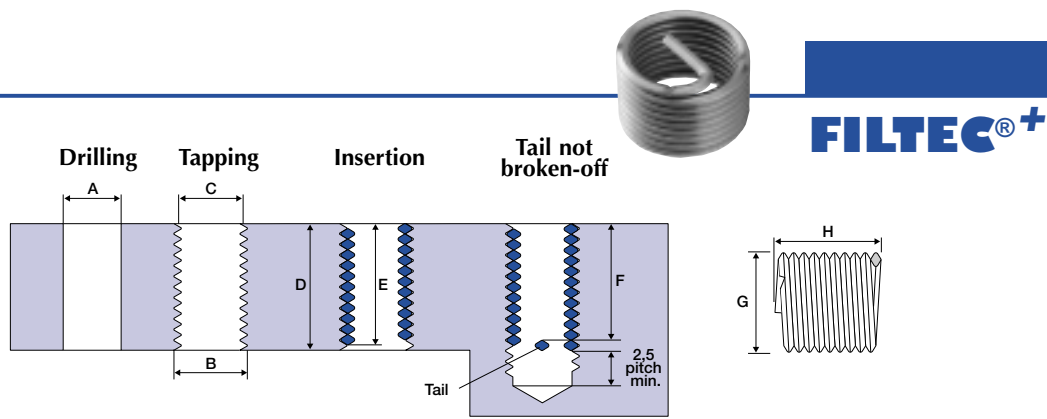
Ø x pitch	x d	D : base tapping length	CODE 127 : Filtec ⁺ 125 : Green Filtec ⁺ 104 : Lockfil ⁺	H : nb. of turns at the initial state Tolerance -0,25	G : Ø initial state min - max	A : Drilling		Tapping	
						Ø drill	Tolerance min max	B : Ø ext. min	C : Ø outer
M 16 x 1,50	0,75 d	12,00	127 16 03 12 00	6,50	18,40 18,80	16,50	16,324 + 0,236	17,948	16,974 + 0,125
	1 d	16,00	127 16 03 16 00	9,00					
	1,25 d	20,00	127 16 03 20 00	11,35					
	1,5 d	24,00	127 16 03 24 00	13,85					
	2 d	32,00	127 16 03 32 00	18,70					
	2,5 d	40,00	127 16 03 40 00	23,65					
M 16 x 2,00	0,75 d	12,00	127 16 05 12 00	4,65	18,80 19,10	16,50	16,433 + 0,300	18,598	17,299 + 0,145
	1 d	16,00	127 16 05 16 00	6,55					
	1,25 d	20,00	127 16 05 20 00	8,40					
	1,5 d	24,00	127 16 05 24 00	10,20					
	2 d	32,00	125 16 05 32 00	13,95					
	2,5 d	40,00	127 16 05 40 00	17,70					
M 18 x 1,50	0,75 d	13,50	127 18 03 13 50	7,30	20,60 21,00	18,50	18,324 + 0,236	19,948	18,974 + 0,125
	1 d	18,00	127 18 03 18 00	9,90					
	1,25 d	22,50	127 18 03 22 50	12,70					
	1,5 d	27,00	127 18 03 27 00	15,55					
	2 d	36,00	127 18 03 36 00	21,05					
M 18 x 2,00	0,75 d	13,50	127 18 05 13 50	5,20	21,00 21,40	18,50	18,433 + 0,300	20,598	19,299 + 0,145
	1 d	18,00	127 18 05 18 00	7,25					
	1,25 d	22,50	127 18 05 22 50	9,10					
	1,5 d	27,00	127 18 05 27 00	11,45					
	2 d	36,00	127 18 05 36 00	15,45					
M 18 x 2,50	0,75 d	13,50	127 18 06 13 50	3,80	21,35 21,70	18,75	18,541 + 0,355	21,248	19,624 + 0,154
	1 d	18,00	127 18 06 18 00	5,60					
	1,25 d	22,50	127 18 06 22 50	6,40					
	1,5 d	27,00	127 18 06 27 00	9,05					
	2 d	36,00	127 18 06 36 00	12,35					
M 20 x 1,50	0,75 d	15,00	127 20 03 13 50	8,15	23,00 23,50	20,50	20,433 + 0,300	22,598	21,299 + 0,145
	1 d	20,00	127 20 03 18 00	11,05					
	1,25 d	25,00	127 20 03 22 50	13,80					
	1,5 d	30,00	127 20 03 27 00	17,20					
	2 d	40,00	127 20 03 36 00	23,10					
M 20 x 2,00	0,75 d	15,00	127 20 05 15 00	6,00	22,90 23,40	20,50	20,433 + 0,300	22,598	21,299 + 0,145
	1 d	20,00	127 20 05 20 00	8,25					
	1,25 d	25,00	127 20 05 25 00	10,45					
	1,5 d	30,00	127 20 05 30 00	12,90					
	2 d	40,00	127 20 05 40 00	17,35					

FILTEC[®]+
METRIC

Ø x pitch	x d	D : base tapping length	CODE 127 : Filtec ⁺ 125 : Filtec ⁺ vert 104 : Lockfil ⁺	H : nb. of turns at the initial state Tolerance -0,25	G : Ø initial state min - max	A : Drilling		Tapping	
						Ø drill	Tolerance min max	B : Ø ext. min	C : Ø outer
M 20 x 2,50	0,75 d	15,00	127 20 06 15 00	4,55	23,35 23,75	20,75	20,541 + 0,355	23,248	21,624 + 0,154
	1 d	20,00	127 20 06 20 00	6,40					
	1,25 d	25,00	127 20 06 25 00	8,10					
	1,5 d	30,00	127 20 06 30 00	10,15					
	2 d	40,00	127 20 06 40 00	13,90					
M 22 x 1,50	0,5 d	11,00	127 22 03 11 00	5,75	25,00 25,50	22,50	22,324 + 0,236	23,948	23,274 + 0,125
	0,75 d	16,50	127 22 03 16 50	9,05					
	1 d	22,00	127 22 03 22 00	12,30					
	1,25 d	27,50	127 22 03 27 50	15,55					
	1,5 d	33,00	127 22 03 33 00	19,00					
M 22 x 2,00	0,75 d	16,50	127 22 05 16 50	6,70	25,00 25,50	22,50	22,433 + 0,300	24,598	23,299 + 0,145
	1 d	22,00	127 22 05 22 00	9,15					
	1,25 d	27,50	127 22 05 27 50	11,55					
	1,5 d	33,00	127 22 05 33 00	14,30					
	2 d	44,00	127 22 05 44 00	19,35					
M 22 x 2,50	0,75 d	16,50	127 22 06 16 50	5,15	25,40 25,80	22,75	22,541 + 0,355	25,248	23,624 + 0,154
	1 d	22,00	127 22 06 22 00	7,10					
	1,25 d	27,50	127 22 06 27 50	9,10					
	1,5 d	33,00	127 22 06 33 00	11,25					
	2 d	44,00	127 22 06 44 00	15,50					
M 24 x 1,50	0,5 d	12,00	127 24 03 12 00	6,35	27,00 27,50	24,50	24,325 + 0,236	25,948	24,974 + 0,135
	0,75 d	18,00	127 24 03 18 00	10,05					
	1 d	24,00	127 24 03 24 00	13,65					
	1,25 d	30,00	127 24 03 30 00	17,15					
	1,5 d	36,00	127 24 03 36 00	20,95					
M 24 x 3,00	0,75 d	18,00	127 24 07 18 00	4,55	28,30 28,80	24,75	24,649 + 0,400	27,897	25,948 + 0,187
	1 d	24,00	127 24 07 24 00	6,25					
	1,25 d	30,00	127 24 07 30 00	8,15					
	1,5 d	36,00	127 24 07 36 00	10,10					
	2 d	48,00	127 24 07 48 00	14,15					
M 26 x 1,50	0,5 d	13,00	127 26 03 13 00	6,80	29,50 30,00	26,50	26,325 + 0,236	27,948	26,974 + 0,135
	0,75 d	19,50	127 26 03 19 50	10,80					
	1 d	26,00	127 26 03 26 00	14,70					
	1,25 d	32,50	127 26 03 32 50	18,45					
	1,5 d	39,00	127 26 03 39 00	22,70					

FILTEC[®]+

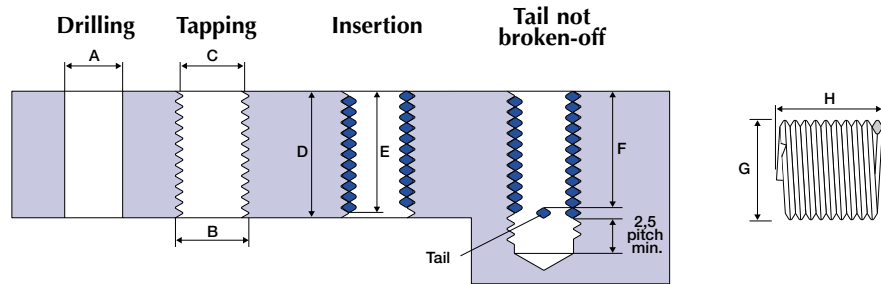
METRIC

Ø x pitch	x d	D : base tapping length	CODE 127 : Filtec ⁺ 125 : Green Filtec ⁺ 104 : Lockfil ⁺	H : nb. of turns at the initial state Tolerance -0,25	G : Ø initial state min - max	A : Drilling		Tapping	
						Ø drill	Tolerance min max	B : Ø ext. min	C : Ø outer
M 27 x 3,00	0,75 d	20,25	127 27 07 20 20	5,05	31,60 32,10	27,75	27,649 + 0,400	30,897	28,948 + 0,187
	1 d	27,00	127 27 07 27 00	7,20					
	1,25 d	33,75	127 27 07 33 70	9,35					
	1,5 d	40,50	127 27 07 40 50	11,60					
	2 d	54,00	127 27 07 54 00	15,65					
M 30 x 3,50	0,75 d	22,50	127 30 08 22 50	4,90	34,90 35,40	31,00	30,757 + 0,450	34,546	32,273 + 0,199
	1 d	30,00	127 30 08 30 00	7,05					
	1,25 d	37,50	127 30 08 37 50	9,05					
	1,5 d	45,00	127 30 08 45 00	11,05					
	2 d	60,00	127 30 08 60 00	15,00					

Some sizes do not appear in the catalogue. Please feel free to contact us for any other request.

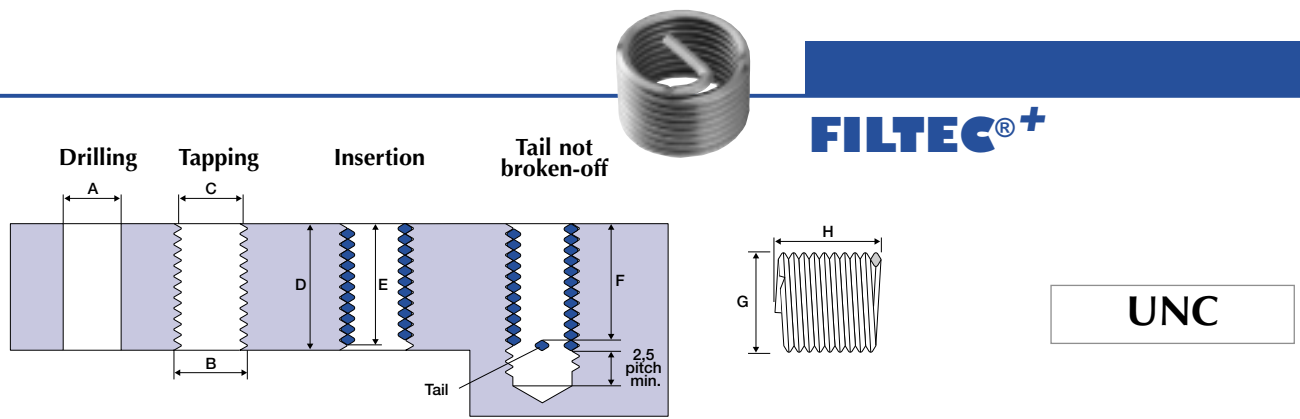

UNC

Ø pitch metric conversion	x d	D : base tapping length inches mm	CODE 128 : Filtec+ 126 : Green Filtec+ 106 : Lockfil+	H : nb. of turns at the initial state Tol. -0,25	G : Ø initial state min - max inches mm	A : Drilling		Tapping	
						Ø drill inches mm	Tolerance min - max inches mm	B : Ø Ext. min inches mm	C : Ø outer min - max inches 3B mm 3B
UNC 2-56 2,18 x 0,453	1 d	0,086 2,2	128 14 0086 20	3,00					
	1,5 d	0,129 3,3	128 14 0129 30	5,25					
	2 d	0,172 4,3	128 14 0172 40	7,40	0,110 2,80 0,116 2,95	0,0960 2,4	0,0899 2,31 0,0961 2,44	0,1118 2,84	0,0976 2,479 0,0989 2,512
	2,5 d	0,215 5,4	128 14 0215 50	9,60					
	3 d	0,258 6,5	128 14 0258 60	11,90					
4-40 2,84 x 0,635	1 d	0,112 2,9	128 15 0112 20	2,75					
	1,5 d	0,168 4,3	128 15 0168 30	4,75					
	2 d	0,224 5,8	128 15 0224 40	6,75	0,142 3,60 0,154 3,90	0,1200 3,1	0,1175 3,00 0,1252 3,15	0,1445 3,67	0,1283 3,259 0,1299 3,300
	2,5 d	0,280 7,2	128 15 0280 50	8,90					
	3 d	0,336 8,5	128 15 0336 60	10,90					
5-40 3,17 x 0,635	1 d	0,125 3,2	128 15 5125 20	3,25					
	1,5 d	0,188 4,8	128 15 5188 30	5,50					
	2 d	0,250 6,4	128 15 5250 40	7,75	0,157 4,00 0,167 4,25	0,1360 3,4	0,1305 3,33 0,1373 3,48	0,1575 4,00	0,1413 3,589 0,1430 3,632
	2,5 d	0,312 7,9	128 15 5312 50	10,00					
	3 d	0,375 9,5	128 15 5375 60	12,25					
6-32 3,51 x 0,794	1 d	0,138 3,5	128 17 0138 20	2,75					
	1,5 d	0,207 5,3	128 17 0207 30	4,75					
	2 d	0,276 7,0	128 17 0276 40	6,90	0,177 4,50 0,187 4,75	0,1495 3,8	0,1448 3,68 0,1527 3,89	0,1787 4,54	0,1583 4,021 0,1601 4,067
	2,5 d	0,345 8,8	128 17 0345 50	8,90					
	3 d	0,414 10,5	128 17 0414 60	10,90					
8-32 4,17 x 0,794	1 d	0,164 4,2	128 19 0164 20	3,50					
	1,5 d	0,246 6,3	128 19 0246 30	6,00					
	2 d	0,328 8,3	128 19 0328 40	8,40	0,205 5,20 0,215 5,45	0,1770 4,5	0,1708 4,34 0,1781 4,52	0,2047 5,20	0,1843 4,681 0,1862 4,730
	2,5 d	0,410 10,5	128 19 0410 50	10,75					
	3 d	0,492 12,5	128 19 0492 60	13,25					
10-24 4,83 x 1,058	1 d	0,190 4,8	128 21 0190 20	2,90					
	1,5 d	0,285 7,2	128 21 0285 30	5,00					
	2 d	0,380 9,6	128 21 0380 40	7,10	0,244 6,20 0,256 6,50	0,2055 5,2	0,1990 5,06 0,2080 5,28	0,2441 6,20	0,2170 5,512 0,2192 5,568
	2,5 d	0,475 12,1	128 21 0475 50	9,25					
	3 d	0,570 14,5	128 21 0570 60	11,40					
1/4-20 6,35 x 1,270	1 d	0,250 6,4	128 23 0250 20	3,40					
	1,5 d	0,375 9,5	128 23 0375 30	5,75					
	2 d	0,500 12,7	128 23 0500 40	8,00	0,315 8,00 0,329 8,35	0,2660 6,8	0,2608 6,62 0,2704 6,86	0,3150 8,00	0,2825 7,176 0,2851 7,242
	2,5 d	0,625 15,9	128 23 0625 50	10,40					
	3 d	0,750 19,0	128 23 0750 60	12,75					

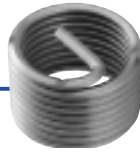
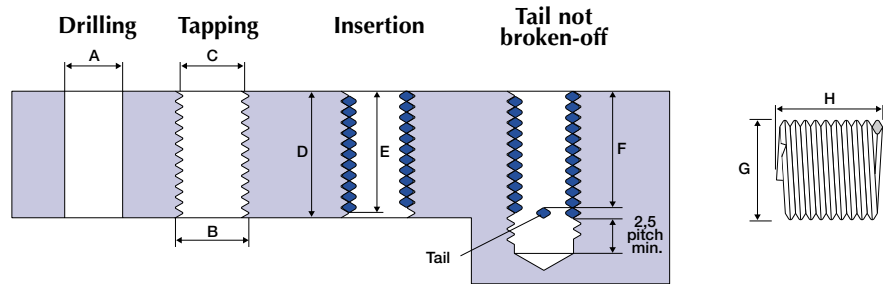
FILTEC®+

UNC

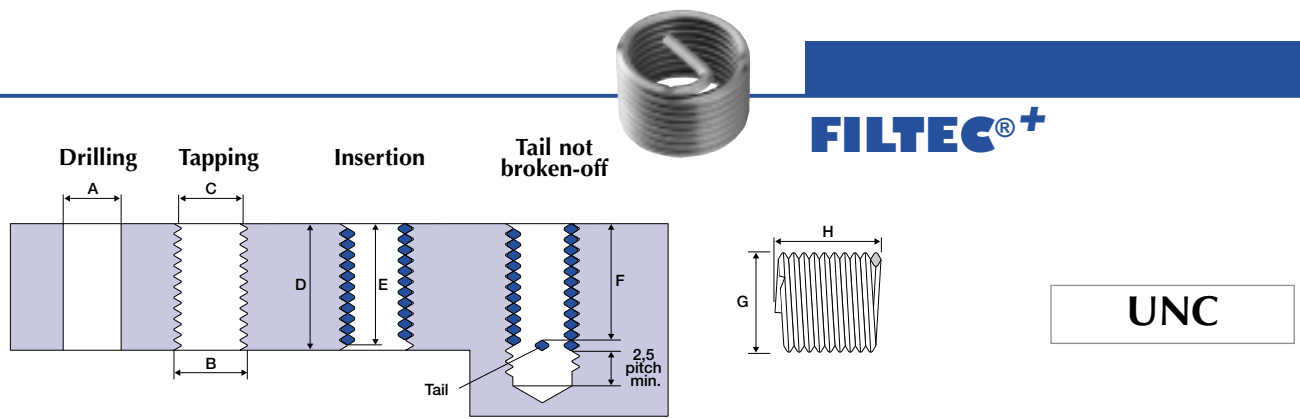
Ø pitch metric conversion	x d	D : base tapping length inches mm	CODE 128 : Filtec+ 126 : Green Filtec+ 106 : Lockfil+	H : nb. of turns at the initial state Tol. -0,25	G : Ø initial state min - max inches mm	A : Drilling		Tapping	
						Ø drill inches mm	Tolerance min - max inches mm	B : Ø Ext. min inches mm	C : Ø outer min - max inches 3B mm 3B
5/16-18 7,94 x 1,411	1 d	0,312 7,9	128 25 0312 20	4,00	0,382 0,398 9,70 10,10	0,3320 8,4	0,3245 0,3342 8,24 8,49	0,3846 9,77	0,3486 0,3515 8,854 8,928
	1,5 d	0,469 11,9	128 25 0469 30	6,60					
	2 d	0,625 15,9	128 25 0625 40	9,25					
	2,5 d	0,781 19,8	128 25 0781 50	11,90					
	3 d	0,937 23,8	128 25 0939 60	14,60					
3/8-16 9,52 x 1,588	1 d	0,375 9,5	128 27 0375 20	4,40	0,453 0,469 11,50 11,90	0,3970 10,1	0,3885 0,3987 9,89 10,12	0,4563 11,59	0,4156 0,4189 10,556 10,640
	1,5 d	0,562 14,3	128 27 0562 30	7,25					
	2 d	0,750 19,1	128 27 0750 40	10,00					
	2,5 d	0,937 23,8	128 27 0938 50	12,90					
	3 d	1,125 28,6	128 27 1125 60	15,75					
7/16-14 11,11 x 1,814	1 d	0,438 11,1	128 29 0438 20	4,50	0,528 0,545 13,40 13,85	0,4531 11,7	0,4530 0,4639 11,51 11,78	0,5303 13,47	0,4839 0,4875 12,291 12,383
	1,5 d	0,656 16,7	128 29 0656 30	7,40					
	2 d	0,875 22,2	128 29 0875 40	10,25					
	2,5 d	1,094 27,8	128 29 1094 50	13,10					
	3 d	1,312 33,3	128 29 1312 60	16,10					
1/2-13 12,70 x 1,954	1 d	0,500 12,7	128 31 0500 20	4,90	0,598 0,614 15,20 15,60	0,5312 13,2	0,5166 0,5273 13,12 13,40	0,6000 15,24	0,5499 0,5537 13,967 14,064
	1,5 d	0,750 19,1	128 31 0750 30	7,90					
	2 d	1,000 25,4	128 31 1000 40	11,00					
	2,5 d	1,250 31,8	128 31 1250 50	14,10					
	3 d	1,500 38,1	128 31 1500 60	17,10					
9/16-12 14,29 x 2,117	1 d	0,562 14,3	128 33 0562 20	5,10	0,669 0,685 17,00 17,40	0,5938 15,0	0,5806 0,5918 14,75 15,03	0,6709 17,04	0,6167 0,6208 15,664 15,768
	1,5 d	0,844 21,5	128 33 0844 30	8,25					
	2 d	1,125 28,6	128 33 1125 40	11,50					
	2,5 d	1,406 35,7	128 33 1406 50	14,75					
	3 d	1,688 42,9	128 33 1688 60	17,90					
5/8-11 15,87 x 2,309	1 d	0,625 15,9	128 35 0625 20	5,25	0,744 0,760 18,90 19,30	0,6562 16,6	0,6447 0,6564 16,38 16,68	0,7433 18,88	0,6841 0,6885 17,376 17,488
	1,5 d	0,937 23,8	128 35 0938 30	8,50					
	2 d	1,250 31,8	128 35 1250 40	11,75					
	2,5 d	1,562 39,7	128 35 1562 50	15,00					
	3 d	1,875 47,6	128 35 1875 60	18,40					
3/4-10 19,05 x 2,540	1 d	0,750 19,1	128 37 0750 20	5,90	0,882 0,898 22,40 22,80	0,7812 19,8	0,7716 0,7838 19,60 19,91	0,8799 22,35	0,8149 0,8196 20,698 20,818
	1,5 d	1,125 28,6	128 37 1125 30	9,40					
	2 d	1,500 38,1	128 37 1500 40	13,00					
	2,5 d	1,875 47,6	128 37 1875 50	16,50					
	3 d	2,250 57,2	128 37 2250 60	20,10					



UNC

Ø pitch metric conversion	x d	D : base tapping length inches mm	CODE 128 : Filtec+ 126 : Green Filtec+ 106 : Lockfil+	H : nb. of turns at the initial state Tol. -0,25	G : Ø initial state min - max inches mm	A : Drilling		Tapping	
						Ø drill inches mm	Tolerance min - max inches mm	B : Ø Ext. min inches mm	C : Ø outer min - max inches 3B mm 3B
7/8-9 22,22 x 2,822	1 d	0,875 22,2	128 39 0875 20	6,25					
	1,5 d	1,312 33,3	128 39 1312 30	10,00					
	2 d	1,750 44,5	128 39 1750 40	13,75	1,024 1,039	0,9062	0,8990 0,9119	1,0193	0,9471 0,9522
	2,5 d	2,187 55,6	128 39 2187 50	17,50	26,00 26,40	23,0	22,84 23,18	25,89	24,056 24,186
	3 d	2,625 66,7	128 39 2625 60	21,25					
1"-8 25,40 x 3,175	1 d	1,000 25,4	128 41 1000 20	6,40					
	1,5 d	1,500 38,1	128 41 1500 30	10,10					
	2 d	2,000 50,8	128 41 2000 40	14,00	1,165 1,185	1,0312	1,0271 1,0421	1,1626	1,0812 1,0868
	2,5 d	2,500 63,5	128 41 2500 50	17,75	29,60 30,10	26,4	26,09 26,47	29,53	27,463 27,605
	3 d	3,000 76,2	128 41 3000 60	21,60					
1 1/8-7 28,57 x 3,629	1 d	1,125 28,6	128 43 1125 20	6,10					
	1,5 d	1,687 42,9	128 43 1687 30	9,90					
	2 d	2,250 57,2	128 43 2250 40	13,60	1,315 1,339	1,1719	1,1559 1,1730	1,3106	1,2178 1,2239
	2,5 d	2,812 71,4	128 43 2812 50	17,50	33,40 34,00	29,5	29,36 29,74	33,29	30,932 31,087
	3 d	3,375 85,7	128 43 3375 60	21,25					
1 1/4-7 31,75 x 3,629	1 d	1,250 31,8	128 45 1250 20	7,00					
	1,5 d	1,875 47,6	128 45 1875 30	11,25					
	2 d	2,500 63,5	128 45 2500 40	15,40	1,441 1,465	1,2969	1,2809 1,2980	1,4354	1,3428 1,3490
	2,5 d	3,125 79,4	128 45 3125 50	19,55	36,60 37,20	32,8	32,54 32,92	36,46	34,107 34,265
	3 d	3,750 95,3	128 45 3750 60	23,80					
1 3/8-6 34,92 x 4,234	1 d	1,375 34,9	128 47 1375 20	6,50					
	1,5 d	2,062 52,4	128 47 2062 30	10,50					
	2 d	2,750 69,9	128 47 2750 40	14,40	1,594 1,622	1,4219	1,4110 1,4310	1,5913	1,4832 1,4900
	2,5 d	3,437 87,3	128 47 3437 50	18,45	40,50 41,20	36,3	35,84 36,35	40,42	37,673 37,846
	3 d	4,125 104,8	128 47 4125 60	22,30					
1 1/2-6 38,10 x 4,234	1 d	1,500 38,1	128 49 1500 20	7,20					
	1,5 d	2,250 57,2	128 49 2250 30	11,50					
	2 d	3,000 76,2	128 49 3000 40	15,90	1,724 1,748	1,5469	1,5360 1,5560	1,7165	1,6082 1,6151
	2,5 d	3,750 95,3	128 49 3750 50	20,15	43,80 44,40	39,5	39,02 39,53	43,60	40,848 41,024
	3 d	4,500 114,3	128 49 4500 60	24,55					

FILTEC[®]+

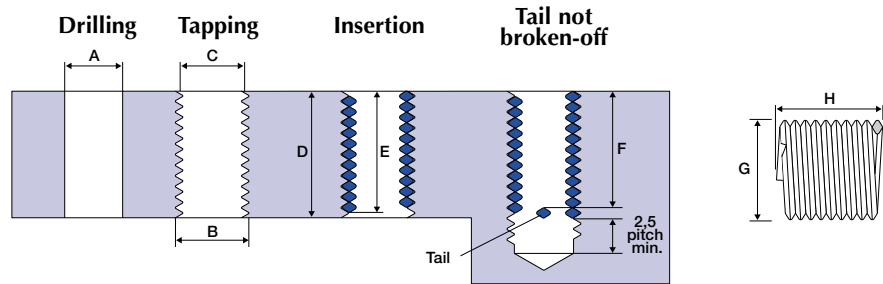
UNF

Ø pitch metric conversion	x d	D : base tapping length inches mm	CODE 128 : Filtec+ 126 : Green Filtec+ 106 : Lockfil+	H : nb. of turns at the initial state Tol. -0,25	G : Ø initial state min - max inches mm	A : Drilling		Tapping	
						Ø drill inches mm	Tolerance min - max inches mm	B : Ø Ext. min inches mm	C : Ø outer min - max inches 3B mm 3B
UNF 6-40 3,51 x 0,635	1 d	0,138 3,5	128 16 1138 20	3,55					
	1,5 d	0,207 5,3	128 16 1207 30	6,10					
	2 d	0,276 7,0	128 16 1276 40	8,55	0,173 0,181	0,1495	0,1435 0,1503	0,1705	0,1543 0,1560
	2,5 d	0,345 8,8	128 16 1345 50	10,95	4,40 4,60	3,7	3,66 3,81	4,33	3,919 3,962
	3 d	0,414 10,5	128 16 1414 60	13,55					
8-36 4,16 x 0,705	1 d	0,164 4,2	128 18 0164 20	4,00					
	1,5 d	0,246 6,3	128 18 0246 30	6,70					
	2 d	0,328 8,3	128 18 0328 40	9,35	0,203 0,211	0,1770	0,1701 0,1771	0,2000	0,1821 0,1840
	2,5 d	0,410 10,5	128 18 0410 50	11,90	5,15 5,35	4,4	4,32 4,47	5,08	4,625 4,674
	3 d	0,492 12,5	128 18 0492 60	14,65					
10-32 4,83 x 0,794	1 d	0,190 4,8	128 20 0190 20	4,20					
	1,5 d	0,285 7,2	128 20 0285 30	7,05					
	2 d	0,380 9,6	128 20 0380 40	9,75	0,234 0,244	0,2031	0,1968 0,2041	0,2307	0,2103 0,2123
	2,5 d	0,475 12,1	128 20 0475 50	12,55	5,95 6,20	5,1	5,00 5,16	5,86	5,342 5,392
	3 d	0,570 14,5	128 20 0570 60	15,25					
1/4-28 6,35 x 0,907	1 d	0,250 6,4	128 24 0250 20	5,10					
	1,5 d	0,375 9,5	128 24 0375 30	8,40					
	2 d	0,500 12,7	128 24 0500 40	11,60	0,301 0,315	0,2638	0,2577 0,2646	0,3012	0,2732 0,2754
	2,5 d	0,625 15,9	128 24 0625 50	14,75	7,65 8,00	6,7	6,55 6,72	7,53	6,939 6,995
	3 d	0,750 19,0	128 24 0750 60	17,95					
5/16-24 7,94 x 1,058	1 d	0,312 7,9	128 26 0312 20	5,65					
	1,5 d	0,469 11,9	128 26 0469 30	9,15					
	2 d	0,625 15,9	128 26 0625 40	12,55	0,372 0,382	0,3281	0,3215 0,3288	0,3665	0,3395 0,3421
	2,5 d	0,781 19,8	128 26 0781 50	16,00	9,45 9,70	8,2	8,17 8,35	9,31	8,623 8,689
	3 d	0,937 23,8	128 26 0937 60	19,50					
3/8-24 9,52 x 1,058	1 d	0,375 9,5	128 28 0375 20	7,10					
	1,5 d	0,562 14,3	128 28 0562 30	11,30					
	2 d	0,750 19,1	128 28 0750 40	15,40	0,437 0,457	0,3906	0,3840 0,3910	0,4291	0,4020 0,4047
	2,5 d	0,938 23,8	128 28 0938 50	19,60	11,10 11,60	9,8	9,75 9,93	10,90	10,211 10,279
	3 d	1,125 28,6	128 28 1125 60	23,75					

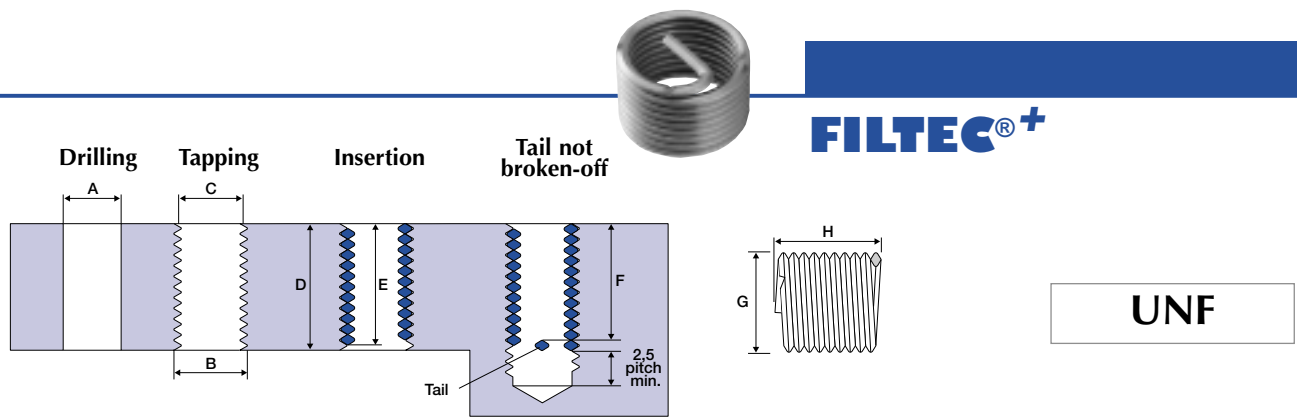

Ø pitch metric conversion	x d	D : base tapping length inches mm	CODE 128 : Filtec+ 126 : Green Filtec+ 106 : Lockfil+	H : nb. of turns at the initial state Tol. -0,25	G : Ø initial state min - max inches mm	A : Drilling			Tapping	
						Ø drill inches mm	Tolerance min - max inches mm	B : Ø Ext. min inches mm	C : Ø outer min - max inches 3B mm 3B	
7/16-20 11,11 x 1,270	1 d	0,438 11,1	128 30 0438 20	6,85	0,508 0,524 12,90 13,30	0,4531 11,5	0,4483 0,4561 11,39 11,59	0,5024 12,76	0,4700 0,4731 11,938 12,017	
	1,5 d	0,656 16,7	128 30 0656 30	11,00						
	2 d	0,875 22,2	128 30 0875 40	15,15						
	2,5 d	1,094 27,8	128 30 1094 50	19,20						
	3 d	1,312 33,3	128 30 1312 60	23,35						
1/2-20 12,70 x 1,270	1 d	0,500 12,7	128 32 0500 20	8,20	0,571 0,587 14,50 14,90	0,5156 13,1	0,5108 0,5186 12,97 13,17	0,5650 14,35	0,5325 0,5357 13,526 13,607	
	1,5 d	0,750 19,1	128 32 0750 30	12,90						
	2 d	1,000 25,4	128 32 1000 40	17,60						
	2,5 d	1,250 31,8	128 32 1250 50	22,30						
	3 d	1,500 38,1	128 32 1500 60	27,00						
9/16-18 14,29 x 1,411	1 d	0,562 14,3	128 34 0562 20	8,20	0,646 0,665 16,40 16,90	0,5781 14,7	0,5745 0,5826 14,59 14,79	0,6346 16,12	0,5986 0,6020 15,204 15,291	
	1,5 d	0,844 21,5	128 34 0844 30	12,85						
	2 d	1,125 28,6	128 34 1125 40	17,60						
	2,5 d	1,406 35,7	128 34 1406 50	22,40						
	3 d	1,687 42,9	128 34 1687 60	27,05						
5/8-18 15,88 x 1,411	1 d	0,625 15,9	128 36 0625 20	9,20	0,717 0,732 18,20 18,60	0,6406 16,3	0,6370 0,6451 16,18 16,38	0,6972 17,71	0,6611 0,6646 16,792 16,881	
	1,5 d	0,937 23,8	128 36 0937 30	14,40						
	2 d	1,250 31,8	128 36 1250 40	19,65						
	2,5 d	1,562 39,7	128 36 1562 50	24,75						
	3 d	1,875 47,6	128 36 1875 60	30,05						
3/4-16 19,05 x 1,588	1 d	0,750 19,1	128 38 0750 20	10,00	0,850 0,870 21,60 22,10	0,7656 19,5	0,7635 0,7720 19,39 19,60	0,8311 21,11	0,7906 0,7945 20,081 20,180	
	1,5 d	1,125 28,6	128 38 1125 30	15,55						
	2 d	1,500 38,1	128 38 1500 40	21,15						
	2,5 d	1,875 47,7	128 38 1875 50	26,70						
	3 d	2,250 57,2	128 38 2250 60	32,35						
7/8-14 22,22 x 1,814	1 d	0,875 22,2	128 40 0875 20	10,30	0,984 1,008 25,00 25,60	0,8906 22,7	0,8905 0,8994 22,62 22,84	0,9677 24,58	0,9214 0,9257 23,404 23,513	
	1,5 d	1,312 33,3	128 40 1312 30	16,10						
	2 d	1,750 44,5	128 40 1750 40	21,90						
	2,5 d	2,187 55,6	128 40 2187 50	27,65						
	3 d	2,625 66,7	128 40 2625 60	33,50						

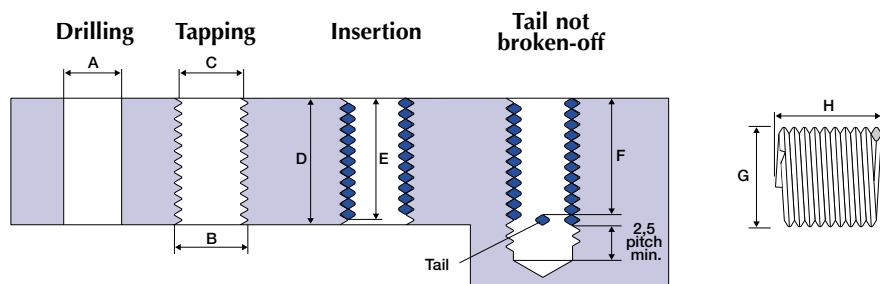

BSP

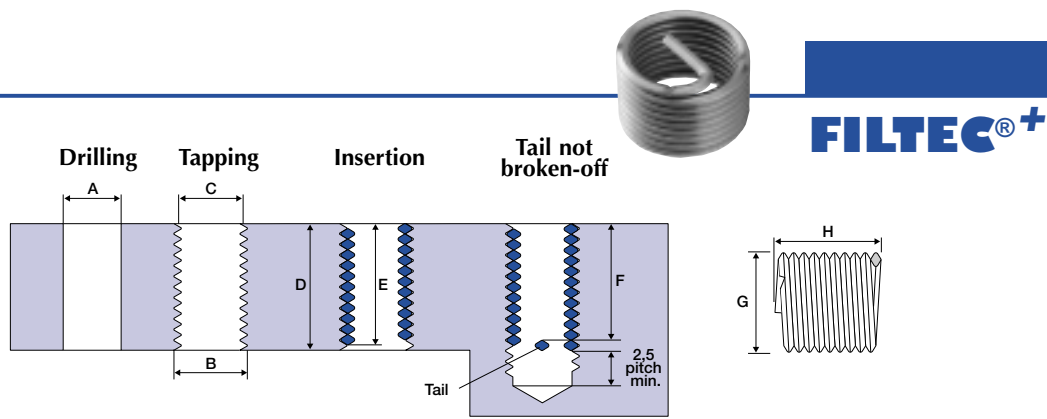
Ø x pitch metric conversion	D : base tapping length mm	CODE 129 : Filtec+ 131 : Green Filtec+	H : nb. of turns at the initial state Tol. -0,25	G : Ø initial state min - max mm	A : Drilling			Tapping	
					Ø drill mm	Tolérances mini - maxi mm	B : Ø ext. min mm	C : Ø outer min - max mm	
1/8-28 9,728 x 0,907	4,8	129 12 0100 30	3,70	11,2 11,6	10,1	9,91 10,16	10,82	10,307 10,389	
	6,4	129 12 0100 40	5,20						
	7,9	129 12 0100 50	6,85						
	9,5	129 12 0100 60	8,40						
1/4-19 13,157 x 1,337	9,5	129 14 0150 30	5,45	15,2 15,7	13,7	13,46 13,72	14,74	14,013 14,112	
	12,7	129 14 0150 40	7,60						
	15,9	129 14 0150 50	9,90						
	19	129 14 0150 60	12,15						
3/8-19 16,662 x 1,337	9,5	129 14 0200 20	5,40	19,0 19,5	17,2	17,02 17,27	18,25	17,518 17,620	
	14,3	129 14 0200 30	8,70						
	19,1	129 14 0200 40	12,10						
	23,8	129 14 0200 50	15,35						
1/2-14 20,955 x 1,814	12,7	129 15 0250 20	5,40	23,7 24,3	21,5	21,34 21,59	23,09	22,118 22,235	
	19,1	129 15 0250 30	8,70						
	25,4	129 15 0250 40	12,00						
	31,8	129 15 0250 50	15,35						
5/8-14 22,911 x 1,814	15,9	129 15 0300 20	7,05	25,6 26,3	23,5	23,24 23,55	25,05	24,074 24,191	
	23,8	129 15 0300 30	11,25						
	31,8	129 15 0300 40	15,40						
	39,7	129 15 0300 50	19,60						
3/4-14 26,441 x 1,814	19,1	129 15 0350 20	8,70	29,3 30,0	27	26,75 27,08	28,59	27,605 27,732	
	28,6	129 15 0350 30	13,60						
	38,1	129 15 0350 40	18,80						
	47,6	129 15 0350 50	23,80						
7/8-14 30,201 x 1,814	22,2	129 15 0400 20	10,35	33,3 34,0	30,7	30,48 30,81	32,35	31,364 31,493	
	33,3	129 15 0400 30	16,20						
	44,5	129 15 0400 40	22,10						
1"-11 33,249 x 2,309	25,4	129 15 0450 20	9,20	37,0 37,8	33,7	33,53 33,91	35,96	34,729 34,867	
	38,1	129 15 0450 30	14,40						
	50,8	129 15 0450 40	19,60						

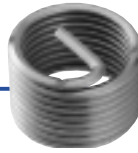
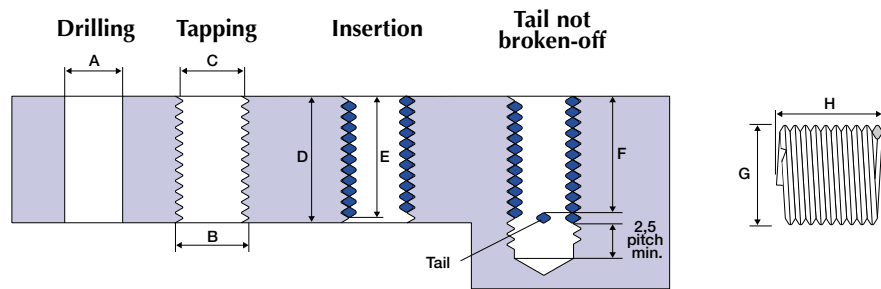

BSW

Ø x pitch metric conversion	x d	D : base tapping length mm	CODE 129 : Filtec+ 131 : Green Filtec+	H : nb. of turns at the initial state Tol. -0,25	G : Ø initial state min - max mm	A : Drilling			Tapping	
						Ø drill mm	Tolérances mini - maxi mm	B : Ø ext. min mm	C : Ø outer min - max mm	
1/4-20 6,350 x 1,270	1 d	6,4	129 22 0100 20	3,40	7,9 8,2	6,7	6,63 6,78	7,84	7,163 7,236	
	1,5 d	9,5	129 22 0100 30	5,80						
	2 d	12,7	129 22 0100 40	8,10						
	2,5 d	15,9	129 22 0100 50	10,50						
5-16-18 7,938 x 1,411	1 d	7,9	129 22 0150 20	4,10	9,7 10,1	8,5	8,33 8,48	9,59	8,839 8,920	
	1,5 d	11,9	129 22 0150 30	6,70						
	2 d	15,9	129 22 0150 40	9,40						
	2,5 d	19,8	129 22 0150 50	12,00						
3/8-16 9,525 x 1,588	1 d	9,5	129 23 0200 20	4,50	11,5 11,9	10,1	9,91 10,11	11,39	10,541 10,630	
	1,5 d	14,3	129 23 0200 30	7,30						
	2 d	19,1	129 23 0200 40	10,20						
	2,5 d	23,8	129 23 0200 50	13,00						
7/16-14 11,113 x 1,814	1 d	11,1	129 23 0250 20	4,65	13,35 13,8	11,7	11,51 11,76	13,24	12,276 12,372	
	1,5 d	16,7	129 23 0250 30	7,65						
	2 d	22,2	129 23 0250 40	10,50						
	2,5 d	27,8	129 23 0250 50	13,45						
1/2-12 12,700 x 2,117	1 d	12,7	129 24 0300 20	4,40	15,3 15,7	13,2	13,08 13,34	15,17	14,054 14,161	
	1,5 d	19,1	129 24 0300 30	7,35						
	2 d	25,4	129 24 0300 40	10,15						
	2,5 d	31,8	129 24 0300 50	13,05						
9/16-12 14,290 x 2,117	1 d	14,3	129 24 0350 20	5,20	16,9 17,3	14,7	14,68 14,94	16,76	15,641 15,751	
	1,5 d	21,5	129 24 0350 30	8,45						
	2 d	28,6	129 24 0350 40	11,65						
	2,5 d	35,7	129 24 0350 50	14,85						
5/8-11 15,876 x 2,309	1 d	15,9	129 24 0400 20	5,45	18,7 19,1	16,6	16,59 16,84	18,57	17,353 17,470	
	1,5 d	23,8	129 24 0400 30	8,75						
	2 d	31,8	129 24 0400 40	12,00						
	2,5 d	39,7	129 24 0400 50	15,45						
3/4-10 19,051 x 2,540	1 d	19,1	129 25 0450 20	6,05	22,2 22,6	20	19,84 20,09	22,02	20,678 20,805	
	1,5 d	28,6	129 25 0450 30	9,65						
	2 d	38,1	129 25 0450 40	13,30						
	2,5 d	47,6	129 25 0450 50	16,95						
7/8-9 22,226 x 2,822	1 d	22,2	129 25 0500 20	6,45	25,7 26,2	23	23,01 23,27	25,52	24,033 24,171	
	1,5 d	33,3	129 25 0500 30	10,20						
	2 d	44,5	129 25 0500 40	14,05						
	2,5 d	55,6	129 25 0500 50	17,90						
1"-8 25,400 x 3,175	1 d	25,4	129 25 0550 20	6,55	29,3 29,8	26,5	26,19 26,52	29,10	27,435 27,582	
	1,5 d	38,1	129 25 0550 30	10,30						
	2 d	50,8	129 25 0550 40	14,20						
	2,5 d	63,5	129 25 0550 50	18,05						

FILTEC^{®+}

BSF

Ø x pitch metric conversion	x d	D : base tapping length mm	CODE 129 : Filtec ⁺ 131 : Green Filtec ⁺	H : nb. of turns at the initial state Tol. -0,25	G : Ø initial state min - max mm	A : Drilling			Tapping		
						Ø drill mm	Tolerances mini - maxi mm	B : Ø ext. min mm	C : Ø outer min - max mm		
1/4-26 6,350 x 0,977	1 d	6,4	129 32 0100 20	4,75	7,6 7,9	6,7	6,53 6,71	7,51	6,977 7,046		
	1,5 d	9,5	129 32 0100 30	7,90							
	2 d	12,7	129 32 0100 40	10,80							
	2,5 d	15,9	129 32 0100 50	13,90							
5/16-22 7,938 x 1,156	1 d	7,9	129 32 0150 20	5,15	9,5 9,8	8,3	8,20 8,38	9,30	8,677 8,755		
	1,5 d	11,9	129 32 0150 30	8,35							
	2 d	15,9	129 32 0150 40	11,55							
	2,5 d	19,8	129 32 0150 50	14,75							
3/8-20 9,525 x 1,270	1 d	9,5	129 33 0200 20	5,85	11,1 11,4	9,9	9,78 9,96	11,02	10,338 10,424		
	1,5 d	14,3	129 33 0200 30	9,40							
	2 d	19,1	129 33 0200 40	12,95							
	2,5 d	23,8	129 33 0200 50	20,05							
7/16-18 11,113 x 1,411	1 d	11,1	129 33 0250 20	6,15	13,0 13,4	11,5	11,43 11,63	12,78	12,014 12,108		
	1,5 d	16,7	129 33 0250 30	9,90							
	2 d	22,2	129 33 0250 40	13,70							
	2,5 d	27,8	129 33 0250 50	17,35							
1/2-16 12,700 x 1,588	1 d	12,7	129 34 0300 20	6,35	14,8 15,3	13,2	13,03 13,26	14,57	13,716 13,818		
	1,5 d	19,1	129 34 0300 30	10,15							
	2 d	25,4	129 34 0300 40	13,90							
	2,5 d	31,8	129 34 0300 50	17,70							
9/16-16 14,288 x 1,588	1 d	14,3	129 34 0350 20	7,30	16,5 17,0	14,7	14,66 14,88	16,16	15,304 15,410		
	1,5 d	21,5	129 34 0350 30	11,55							
	2 d	28,6	129 34 0350 40	15,70							
	2,5 d	35,7	129 34 0350 50	20,10							
5/8-14 15,875 x 1,814	1 d	15,9	129 34 0400 20	7,10	18,3 18,9	16,4	16,26 16,49	18,01	17,038 17,150		
	1,5 d	23,8	129 34 0400 30	11,25							
	2 d	31,8	129 34 0400 40	15,45							
	2,5 d	39,7	129 34 0400 50	19,50							
3/4-12 19,050 x 2,117	1 d	19,1	129 35 0450 20	7,35	21,8 22,4	19,5	19,43 19,69	21,53	20,404 20,528		
	1,5 d	28,6	129 35 0450 30	11,65							
	2 d	38,1	129 35 0450 40	15,95							
	2,5 d	47,6	129 35 0450 50	20,25							
7/8-11 22,225 x 2,309	1 d	22,2	129 35 0500 20	7,95	25,3 26,1	22,7	22,61 22,86	24,94	23,703 23,835		
	1,5 d	33,3	129 35 0500 30	12,45							
	2 d	44,5	129 35 0500 40	17,15							
	2,5 d	55,6	129 35 0500 50	21,75							
1"-10 25,400 x 2,540	1 d	25,4	129 35 0550 20	8,30	28,6 29,4	26,5	26,19 26,52	28,38	27,028 27,170		
	1,5 d	38,1	129 35 0550 30	13,20							
	2 d	50,8	129 35 0550 40	18,05							
	2,5 d	63,5	129 35 0550 50	22,80							



FILTEC[®]+



Strip feed thread inserts

FILTEC⁺ and FILTEC thread inserts can be directly installed in a plastic strip rolled around a coil. This principle enables thread inserts to be used more efficiently and faster.

APPLICATIONS

Strip feed thread inserts are adopted in medium and high scale production, mostly on fixed working post (with no problem of clutter).



PRODUCT SPECIFICATIONS

The plastic strips on which the thread inserts are installed are delivered by coil.

Main advantages are :

- Working conditions improved
- A better ergonomics
- No risk in mixing the thread inserts
- Easier to handle

These advantages enable an easier and productive insertion.

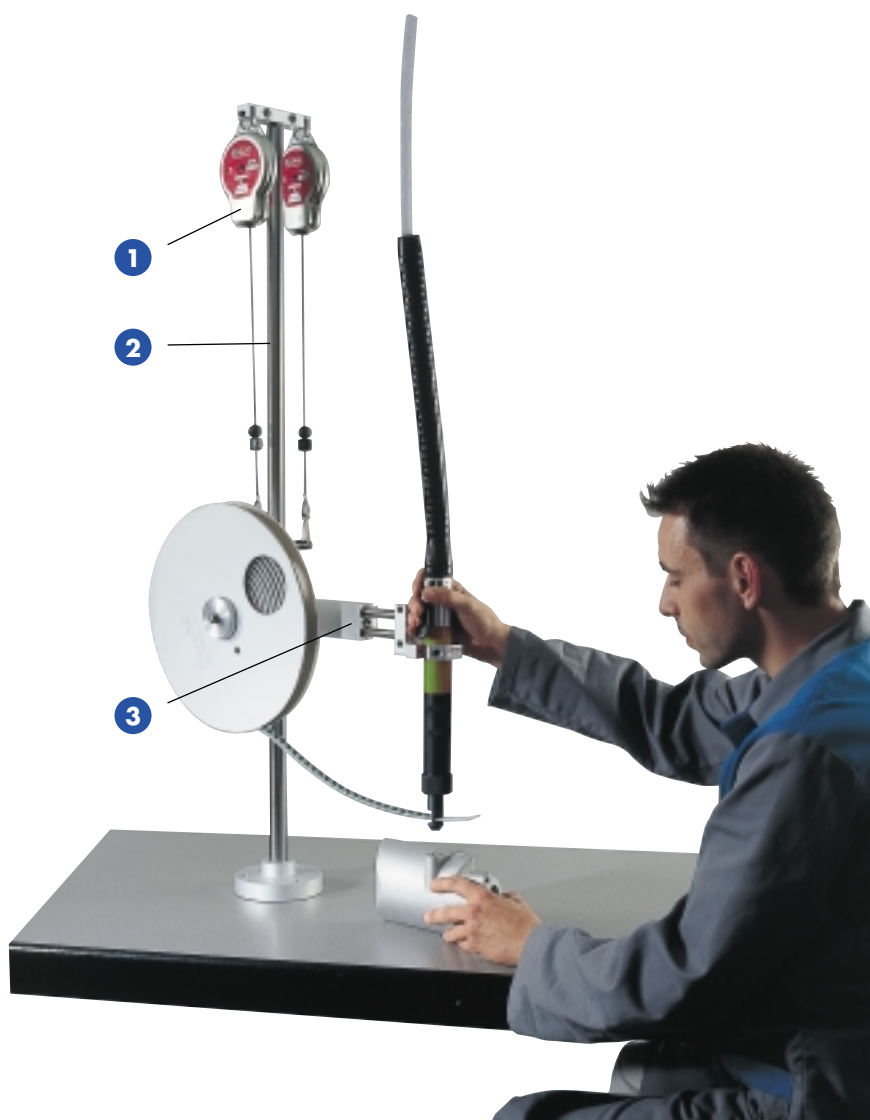

- 1 Balancing
- 2 Support
- 3 Articulated arm

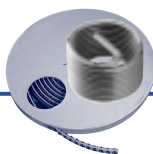
METRIC
PRODUCT RANGE

Our strip feed thread inserts range includes:

- Metric FILTEC⁺ thread inserts from M3 to M10
- Metric Green FILTEC⁺ from M3 to M10
- Metric LOCKFIL⁺ from M3 to M10

For any other request, feel free to contact us.

nominal Ø and pitch	nominal length		Thread inserts quantity 320 mm coil	Thread inserts quantity 220 mm coil	CODE	CODE	CODE
					FILTEC ⁺	Green FILTEC ⁺	LOCKFIL ⁺
M 3 x 0,50	1 d	3,00	4000	1000	118 03 50 03 00	117 03 50 03 00	116 03 50 03 00
M 3 x 0,50	1,5 d	4,50	2500	1000	118 03 50 04 50	117 03 50 04 50	116 03 50 04 50
M 3 x 0,50	2 d	6,00	2000	1000	118 03 50 06 00	117 03 50 06 00	116 03 50 06 00
M 4 x 0,70	1 d	4,00	2000	1000	118 04 70 04 00	117 04 70 04 00	116 04 70 04 00
M 4 x 0,70	1,5 d	6,00	1500	1000	118 04 70 06 00	117 04 70 06 00	116 04 70 06 00
M 4 x 0,70	2 d	8,00	1300	1000	118 04 70 08 00	117 04 70 08 00	116 04 70 08 00
M 5 x 0,80	1 d	5,00	1500	1000	118 05 80 05 00	117 05 80 05 00	116 05 80 05 00
M 5 x 0,80	1,5 d	7,50	1000	-	118 05 80 07 50	117 05 80 07 50	116 05 80 07 50
M 5 x 0,80	2 d	10,00	750	-	118 05 80 10 00	117 05 80 10 00	116 05 80 10 00
M 6 x 1,00	1 d	6,00	1000	-	118 06 01 06 00	117 06 01 06 00	116 06 01 06 00
M 6 x 1,00	1,5 d	9,00	750	-	118 06 01 09 00	117 06 01 09 00	116 06 01 09 00
M 6 x 1,00	2 d	12,00	500	-	118 06 01 12 00	117 06 01 12 00	116 06 01 12 00
M 8 x 1,25	1 d	8,00	600	-	118 08 02 08 00	117 08 02 08 00	116 08 02 08 00
M 8 x 1,25	1,5 d	12,00	400	-	118 08 02 12 00	117 08 02 12 00	116 08 02 12 00
M 8 x 1,25	2 d	16,00	300	-	118 08 02 16 00	117 08 02 16 00	116 08 02 16 00
M 10 x 1,50	1 d	10,00	400	-	118 10 03 10 00	117 10 03 10 00	116 10 03 10 00
M 10 x 1,50	1,5 d	15,00	250	-	118 10 03 15 00	117 10 03 15 00	116 10 03 15 00
M 10 x 1,50	2 d	20,00	200	-	118 10 03 20 00	117 10 03 20 00	116 10 03 20 00



FILTEC[®]+

NOVADRILL Drills

A range of drills to prepare the FILTEC⁺ thread insert installation.
A precise drilling guarantees a precise tapping.

APPLICATIONS

Drilling of holes before tapping and inserting the thread inserts.



Drills can be used for the different ranges of thread inserts.



PRODUCT RANGE

METRIC

Thread Ø and pitch	Ø	CODE
M 2 x 0,40	2,10	F 02 COY 02100
M 2,5 x 0,45	2,60	F 02 COY 02600
M 3 x 0,50	3,20	F 02 COY 03200
M 3,5 x 0,60	3,70	F 02 COY 03700
M 4 x 0,70	4,20	F 02 COY 04200
M 5 x 0,80	5,20	F 02 COY 05200
M 6 x 1,00	6,30	F 02 COY 06300
M 7 x 1,00	7,30	F 02 COY 07300
M 8 x 1,00	8,30	F 02 COY 08300
M 8 x 1,25	8,40	F 02 COY 08400
M 9 x 1,25	9,40	F 02 COY 09400
M 10 x 1,00	10,30	F 01 COY 10300
M 10 x 1,25	10,40	F 01 COY 10400
M 10 x 1,50	10,50	F 02 COY 10500
M 11 x 1,50	11,50	F 01 COY 11500
M 12 x 1,00	12,30	F 01 COY 12300
M 12 x 1,25	12,40	F 01 COY 12400
M 12 x 1,50	12,50	F 01 COY 12500
M 12 x 1,75	12,50	F 01 COY 12500
M 14 x 1,50	14,50	F 01 COY 14500
M 14 x 2,00	14,50	F 01 COY 14500
M 16 x 1,50	16,50	F 01 COY 16500
M 16 x 2,00	16,50	F 01 COY 16500
M 18 x 1,50	18,50	F 01 COY 18500
M 18 x 2,00	18,50	F 01 COY 18500
M 18 x 2,50	18,75	F 01 NOO 18750
M 20 x 1,50	20,50	F 01 NOO 20500
M 20 x 2,00	20,50	F 01 NOO 20500
M 20 x 2,50	20,75	F 01 NOO 20750

Thread Ø and pitch	Ø	CODE
M 22 x 1,50	22,50	F 01 NOO 22500
M 22 x 2,00	22,50	F 01 NOO 22500
M 22 x 2,50	22,75	F 01 NOO 22750
M 24 x 1,50	24,50	F 01 NOO 24500
M 24 x 2,00	24,50	F 01 NOO 24500
M 24 x 3,00	24,75	F 01 NOO 24750
M 26 x 1,50	26,50	F 01 NOO 26500
M 27 x 1,50	27,50	F 01 NOO 27500
M 27 x 2,00	27,50	F 01 NOO 27500
M 27 x 3,00	27,75	F 01 NOO 27750
M 28 x 1,50	28,50	F 01 NOO 28500
M 30 x 1,50	30,50	F 01 NOO 30500
M 30 x 2,00	30,50	F 01 NOO 30500
M 30 x 3,50	31,00	F 01 NOO 31000
M 32 x 1,50	32,50	F 01 NOO 32500
M 33 x 2,00	33,50	F 01 NOO 33500
M 33 x 3,00	34,00	F 01 NOO 34000
M 33 x 3,50	34,00	F 01 NOO 34000
M 36 x 1,50	36,50	F 01 NOO 36500
M 36 x 2,00	36,50	F 01 NOO 36500
M 36 x 3,00	37,00	F 01 NOO 37000
M 36 x 4,00	37,00	F 01 NOO 37000
M 39 x 3,00	40,00	F 01 NOO 40000
M 39 x 4,00	40,00	F 01 NOO 40000
M 42 x 3,00	43,00	F 01 NOO 43000
M 42 x 4,50	43,00	F 01 NOO 43000

UNC-UNF

Thread Ø and pitch	Ø	CODE
UNC		
2-56	2,40	F 02 COY 02400
4-40	3,10	F 02 COY 03100
5-40	3,40	F 02 COY 03400
6-32	3,80	F 02 COY 03800
8-32	4,50	F 02 COY 04500
10-24	5,20	F 02 COY 05200
1/4 - 20	6,80	F 02 COY 06800
5/16 - 18	8,40	F 02 COY 08400
3/8 - 16	10,10	F 01 COY 10100
7/16 - 14	11,70	F 01 COY 11700
1/2 - 13	13,20	F 01 NOO 13200
9/16 - 12	15,00	F 01 COY 15000
5/8 - 11	16,60	F 01 NOO 16600
3/4 - 10	19,80	F 01 NOO 19800
7/8 - 9	23,00	F 01 NOO 23000
1"-8	26,25	F 01 NOO 26250
1"1/8-7	29,50	F 01 NOO 29500
1"3/8-6	36,00	F 01 NOO 36000
1"1/2-6	39,50	F 01 NOO 39500
UNF		
6-40	3,70	F 02 COY 03700
8-36	4,40	F 02 COY 04400
10-32	5,10	F 02 COY 05100
1/4-28	6,70	F 02 COY 06700
5/16-24	8,20	F 02 COY 08200
3/8-24	9,80	F 02 COY 09800
7/16-20	11,50	F 02 COY 11500
1/2-20	13,10	F 01 NOO 13100
9/16-18	14,70	F 01 COY 14700
5/8-18	16,30	F 01 NOO 16300
3/4-16	19,50	F 01 COY 19500
7/8-14	22,70	F 01 NOO 22700
1"-14	26,00	F 01 NOO 26000
1"-12	26,00	F 01 NOO 26000
1"1/8-12	29,00	F 01 NOO 29000
1"3/8-12	35,50	F 01 NOO 35500

**BSP-BSW
BSF**

Thread Ø and pitch	Ø	CODE
BSP		
1/8-28	10,10	F 01 COY 10100
1/4-19	13,70	F 01 COY 13700
3/8-19	17,20	F 01 NOO 17200
1/2-14	21,50	F 01 NOO 21500
5/8-14	23,50	F 01 NOO 23500
3/4-14	27,00	F 01 NOO 27000
7/8-14	30,50	F 01 NOO 30500
1"-11	33,50	F 01 NOO 33500
BSW		
1/4-20	6,70	F 02 COY 06700
5/16-18	8,50	F 02 COY 08500
3/8-16	10,10	F 01 COY 10100
7/16-14	11,70	F 01 COY 11700
1/2-12	13,20	F 01 NOO 13200
9/16-12	14,70	F 01 COY 14700
5/8-11	16,60	F 01 NOO 16600
3/4-10	20,00	F 01 COY 20000
7/8-9	23,00	F 01 NOO 23000
1"-8	26,50	F 01 NOO 26500
BSF		
1/4-26	6,70	F 02 COY 06700
5/16-22	8,30	F 02 COY 08300
3/8-20	9,90	F 02 COY 09900
7/16-18	11,50	F 02 COY 11500
1/2-16	13,20	F 01 NOO 13200
9/16-16	14,70	F 01 COY 14700
5/8-14	16,40	F 01 NOO 16400
3/4-12	19,50	F 01 COY 19500
7/8-11	22,70	F 01 NOO 22700
1"-10	26,50	F 01 NOO 26500



FILTEC[®]+

Taps

APPLICATIONS

In order to receive the FILTEC⁺ thread insert, the tapping should be made with a specially designed FILTEC⁺ tap.

PRODUCT SPECIFICATIONS

- Specifically adapted for thread inserts, FILTEC⁺ tap is over dimensioned compared with a classical screw tap.
- This tap can be handled manually or adapted on a tool.



FILTEC⁺ tap can be used for the different ranges of thread inserts.





Selection of a tap

These 5 types of taps can be selected according to various criteria defined in the table below.

XX Optimum use

X Possible use

0 Not recommended

		Gun section (Code GUN) Prefix 203	Spiral gudgeon (Code GH) Prefix 204	Undersized tap (Code EB) Prefix 201	Finishing tap without run-out (Code SE) Prefix 202	Finishing tap with run-out (Code AE) Prefix 200
Usable tap						
Advantages		With its carefully designed profile, chips can be pushed out of the open ended hole. The result is a clean thread with no stuffing of chips during the operation.	Ideal for blind holes, this tap extracts chips from the hole and avoids stuffing.	It should be used before the finishing tap without run-out and particularly with hard materials and pitches >200. It can not be used alone.	It should be used after undersized tap.	This standard tap is commonly used, especially for manual tapping.
Type of hole	Open	XX	0	X	X	X
	Blind	0	XX	X	X	X
Manual tapping		XX	X	X	X	XX
Tool tapping		XX	XX	XX	XX	X
Soft material R < 80 kg		XX	XX	X	X	XX
Hard material R > 80 kg		XX	X	XX	XX	0
pitch < 200		XX	X	X	X	XX
pitch > 200		0	0	XX	XX	0



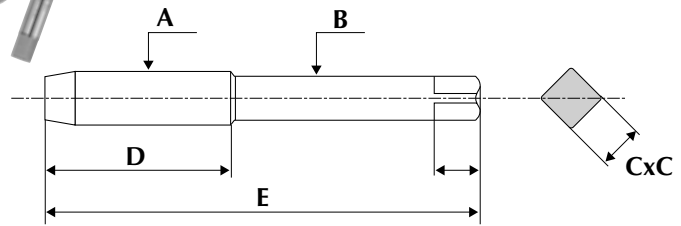

FILTEC[®]
METRIC

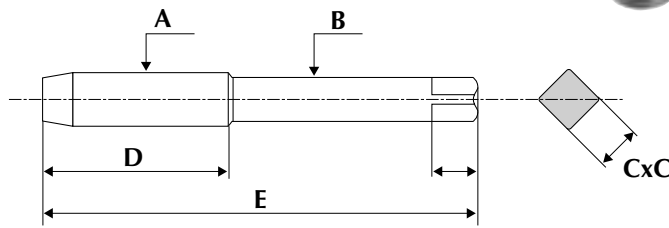
Ø and nominal pitch	A Wall Ø in mm	B Tail Ø in mm	C x C Square dimen- sion (mm)	D Threaded length (mm)	E Total length (mm)	CODE
						200 : AE - 201 : EB 202 : SE - 203 : GUN 204 : GH
M 2 x 0,40	2,50	2,80	2,00	11	46	... 02 40 00 00
M 2,5 x 0,45	3,11	3,15	2,50	13	48	... 02 45 00 00
M 3 x 0,50	3,67	4,00	3,15	16	53	... 03 50 00 00
M 3,5 x 0,60	4,31	4,50	3,55	16	53	... 04 60 00 00
M 4 x 0,70	4,94	5,00	4,00	15	58	... 04 70 00 00
M 5 x 0,80	6,07	6,30	5,00	17	66	... 05 80 00 00
M 6 x 1,00	7,34	8,00	6,30	20	72	... 06 01 00 00
M 7 x 1,00	8,34	9,00	7,10	20	72	... 07 01 00 00
M 8 x 1,00	9,34	10,00	8,00	22	80	... 08 01 00 00
M 8 x 1,25	9,67	10,00	8,00	22	80	... 08 02 00 00
M 9 x 1,25	10,67	8,00	6,30	23	85	... 09 02 00 00
M 10 x 1,00	11,34	8,00	6,30	23	85	... 10 01 00 00
M 10 x 1,25	11,67	8,00	6,30	23	85	... 10 02 00 00
M 10 x 1,50	12,01	9,00	7,10	26	89	... 10 03 00 00
M 11 x 1,50	13,01	9,00	7,10	26	89	... 11 03 00 00
M 12 x 1,00	13,33	11,20	9,00	27	95	... 12 01 00 00
M 12 x 1,25	13,67	11,20	9,00	27	95	... 12 02 00 00
M 12 x 1,50	14,01	11,20	9,00	27	95	... 12 03 00 00
M 12 x 1,75	14,33	11,20	9,00	27	95	... 12 04 00 00
M 14 x 1,25	15,67	12,50	10,00	29	102	... 14 02 00 00
M 14 x 1,50	16,01	12,50	10,00	29	102	... 14 03 00 00
M 14 x 2,00	16,66	12,50	10,00	29	102	... 14 05 00 00
M 16 x 1,50	18,01	14,00	11,20	34	112	... 16 03 00 00
M 16 x 2,00	18,66	14,00	11,20	34	112	... 16 05 00 00
M 18 x 1,50	20,01	14,00	11,20	34	112	... 18 03 00 00
M 18 x 2,00	20,66	14,00	11,20	34	112	... 18 05 00 00
M 18 x 2,50	21,31	16,00	12,50	35	118	... 18 06 00 00
M 20 x 1,50	22,01	16,00	12,50	35	118	... 20 03 00 00
M 20 x 2,00	22,66	16,00	12,50	35	118	... 20 05 00 00
M 20 x 2,50	23,31	16,00	12,50	35	118	... 20 06 00 00
M 22 x 1,50	24,01	18,00	14,00	42	130	... 22 03 00 00
M 22 x 2,00	24,66	18,00	14,00	42	130	... 22 05 00 00
M 22 x 2,50	25,31	18,00	14,00	42	130	... 22 06 00 00
M 24 x 1,50	26,01	18,00	14,00	42	130	... 24 03 00 00
M 24 x 2,00	26,66	20,00	16,00	34	127	... 24 05 00 00
M 24 x 3,00	27,97	20,00	16,00	42	135	... 24 07 00 00
M 26 x 1,50	28,01	20,00	16,00	34	127	... 26 03 00 00
M 27 x 1,50	29,01	20,00	16,00	34	127	... 27 03 00 00
M 27 x 2,00	29,66	20,00	16,00	34	127	... 27 05 00 00
M 27 x 3,00	30,97	22,40	18,00	48	151	... 27 07 00 00
M 28 x 1,50	30,01	20,00	16,00	34	127	... 28 03 00 00
M 30 x 1,50	32,01	22,40	18,00	34	137	... 30 03 00 00
M 30 x 2,00	32,66	22,40	18,00	34	137	... 30 05 00 00
M 30 x 3,50	34,63	25,00	20,00	54	162	... 30 08 00 00
M 32 x 1,50	34,01	25,00	20,00	36	144	... 32 03 00 00
M 33 x 2,00	35,66	25,00	20,00	36	144	... 33 05 00 00
M 33 x 3,00	36,97	25,00	20,00	54	162	... 33 07 00 00
M 33 x 3,50	37,63	28,00	22,40	57	170	... 33 08 00 00
M 36 x 1,50	38,01	28,00	22,40	36	149	... 36 03 00 00
M 36 x 2,00	38,66	28,00	22,40	36	149	... 36 05 00 00
M 36 x 3,00	39,97	28,00	22,40	57	170	... 36 07 00 00
M 36 x 4,00	44,28	28,00	22,40	57	170	... 36 09 00 00
M 39 x 3,00	42,97	31,50	25,00	63	187	... 39 07 00 00
M 39 x 4,00	44,28	31,50	25,00	63	187	... 39 09 00 00
M 42 x 3,00	45,97	31,50	25,00	63	187	... 42 07 00 00
M 42 x 4,50	47,94	31,50	25,00	63	187	... 42 10 00 00

FILTEC[®]+
UNC-UNF

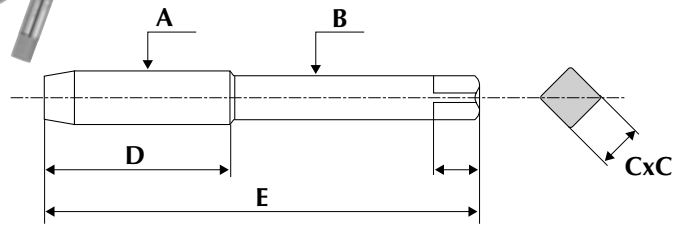
Ø and nominal pitch		A Wall Ø in mm	B Tail Ø in mm	C x C Square dimen- sion (mm)	D Threaded length (mm)	E Total length (mm)	CODE 220 : AE - 221 : EB 222 : SE - 223 : GUN 224 : GH
Inches	Metric conversion						
UNC							
2-56	2,18 x 0,453	2,790	2,8	2,24	9,5	44,5	... 12 10 00 00
4-40	2,84 x 0,635	3,690	4	3,15	16	53	... 15 10 00 00
5-40	3,17 x 0,635	4,025	4	3,15	16	53	... 14 10 00 00
6-32	3,51 x 0,794	4,565	5	4	15	58	... 17 10 00 00
8-32	4,17 x 0,794	5,225	5,6	4,5	16	62	... 19 10 00 00
10-24	4,83 x 1,058	6,235	6,3	5	17	66	... 21 10 00 00
1/4-20	6,35 x 1,270	8,040	8	6,3	20	72	... 23 20 00 00
5/16-18	7,94 x 1,411	9,810	10	8	22	80	... 25 20 00 00
3/8-16	9,52 x 1,588	11,635	8	6,3	23	85	... 27 30 00 00
7/16-14	11,11 x 1,814	13,520	11,2	9	27	95	... 29 30 00 00
1/2-13	12,70 x 1,954	15,295	12,5	10	29	102	... 31 40 00 00
9/16-12	14,29 x 2,117	17,095	14	11,2	34	112	... 33 40 00 00
5/8-11	15,87 x 2,309	18,935	14	11,2	34	112	... 35 40 00 00
3/4-10	19,05 x 2,540	22,415	16	12,5	35	118	... 37 50 00 00
7/8-9	22,22 x 2,822	25,960	18	14	42	130	... 39 50 00 00
1"-8	25,40 x 3,175	29,600	20	16	45	138	... 41 50 00 00
1 1/8-7	28,57 x 3,629	33,370	22,4	18	48	151	... 43 50 00 00
1 1/4-7	31,75 x 3,629	36,545	25	20	54	162	... 45 50 00 00
1 3/8-6	34,92 x 4,234	40,515	28	22,4	57	170	... 47 50 00 00
1 1/2-6	38,10 x 4,234	43,690	31,5	25	63	187	... 49 50 00 00
UNF							
6-40	3,51 x 0,635	4,355	4,5	3,55	16	53	... 16 10 00 00
8-36	4,16 x 0,705	5,110	5,6	4,5	16	62	... 18 10 00 00
10-32	4,83 x 0,794	5,885	6,3	5	17	66	... 20 10 00 00
1/4-28	6,35 x 0,907	7,560	8	6,3	20	72	... 24 20 00 00
5/16-24	7,94 x 1,058	9,350	10	8	22	80	... 26 20 00 00
3/8-24	9,52 x 1,058	10,940	8	6,3	23	85	... 28 30 00 00
7/16-20	11,11 x 1,270	12,805	9	7,1	26	89	... 30 30 00 00
1/2-20	12,70 x 1,270	14,395	11,2	9	27	95	... 32 40 00 00
9/16-18	14,29 x 1,411	16,170	12,5	10	29	102	... 34 40 00 00
5/8-18	15,88 x 1,411	17,700	14	11,2	34	112	... 36 40 00 00
3/4-16	19,05 x 1,588	21,170	16	12,5	35	118	... 38 50 00 00
7/8-14	22,22 x 1,814	24,640	18	14	42	180	... 40 50 00 00
1"-14	25,40 x 1,814	27,820	20	16	34	127	... 52 50 00 00
1"-12	25,40 x 2,117	28,215	20	16	34	127	... 42 50 00 00
1 1/8-12	28,57 x 2,117	31,935	22,4	18	34	137	... 44 50 00 00
1 1/4-12	31,75 x 2,117	34,570	25	20	36	144	... 46 50 00 00
1 3/8-12	34,92 x 2,117	37,700	28	22,4	36	149	... 48 50 00 00
1 1/2-12	38,10 x 2,117	40,925	28	22,4	36	149	... 50 50 00 00

FILTEC®+
**BSP
BSW-BSF**

Ø and nominal pitch		A Wall Ø in mm	B Tail Ø in mm	C x C Square dimen- sion (mm)	D Threaded length (mm)	E Total length (mm)	CODE 230 : AE - 231 : EB 232 : SE
Inches	Metric conversion						
BSP							
1/8-28	9,728 x 0,907	10,309	8	6,3	15	59	... 120 100 00
1/4-19	13,157 x 1,337	14,013	10	8	19	67	... 140 150 00
3/8-19	16,662 x 1,337	17,518	12,5	10	21	75	... 140 200 00
1/2-14	20,955 x 1,814	22,117	16	12,5	26	87	... 150 250 00
5/8-14	22,911 x 1,814	24,073	18	14	26	91	... 150 300 00
3/4-14	26,441 x 1,814	27,603	20	16	28	96	... 150 350 00
7/8-14	30,201 x 1,814	31,363	22,4	18	29	102	... 150 400 00
1"-11	33,249 x 2,309	34,728	25	20	33	109	... 150 450 00
BSW							
1/4-20	6,350 x 1,270	7,163	8	6,3	20	72	... 220 100 00
5/16-18	7,938 x 1,411	8,839	10	8	22	80	... 220 150 00
3/8-16	9,525 x 1,588	10,541	8	6,3	23	85	... 230 200 00
7/16-14	11,113 x 1,814	12,276	11,2	9	27	95	... 230 250 00
1/2-12	12,700 x 2,117	14,054	12,5	10	29	102	... 240 300 00
9/16-12	14,290 x 2,117	15,641	12,5	10	29	102	... 240 350 00
5/8-11	15,876 x 2,309	17,353	14	11,2	34	112	... 240 400 00
3/4-10	19,051 x 2,540	20,678	16	12,5	35	118	... 250 450 00
7/8-9	22,226 x 2,822	24,033	18	14	42	130	... 250 500 00
1"-8	25,400 x 3,175	27,435	20	16	45	138	... 250 550 00
BSF							
1/4-26	6,350 x 0,977	6,975	8	6,3	20	72	... 320 100 00
5/16-22	7,938 x 1,156	8,676	10	8	22	80	... 320 150 00
3/8-20	9,525 x 1,270	10,337	8	6,3	23	85	... 330 200 00
7/16-18	11,113 x 1,411	12,015	9	7,1	26	89	... 330 250 00
1/2-16	12,700 x 1,588	13,716	11,2	9	27	95	... 340 300 00
9/16-16	14,288 x 1,588	15,303	12,5	10	29	102	... 340 350 00
5/8-14	15,875 x 1,814	17,036	14	11,2	34	112	... 340 400 00
3/4-12	19,050 x 2,117	20,404	16	12,5	35	118	... 350 450 00
7/8-11	22,225 x 2,309	23,702	18	14	42	130	... 350 500 00
1"-10	25,400 x 2,540	27,025	20	16	45	138	... 350 550 00



FILTEC[®]+

Control plug gauges



A range of tools specially dedicated to control tapping before fitting thread inserts into it.

APPLICATIONS

FILTEC⁺ control plug gauges are designed to check tapping conformity before insertion of thread inserts.



Control plug gauges can be used for the different ranges of thread inserts.

PRODUCT SPECIFICATIONS

The FILTEC⁺ control plug gauge is made up of two parts one called "go" and the other called "not go".

1

"Not go" threaded gauge

The "not go" part controls the thread outer diameter.

It should not be possible to screw in manually the "not go" threaded gauge more than two threads deep, into one side or the other of the controlled tapping, without employing particular strength (nor should it go completely through a threading with less than 3 threads).

2

"Go" threaded gauge

The "go" part controls :

- thread outer diameter
- thread bottom diameter

It should be possible to screw in manually the "go" threaded gauge the whole length of the tapping to be controlled, without employing particular strength.

Importance to control after tapping

Using FILTEC⁺ control plug gauge is highly recommended to control tapping quality.

A bad tapping may lead to :

- Problems in assembling thread inserts
- A lack of conformity in final tapping when inserting the screw.

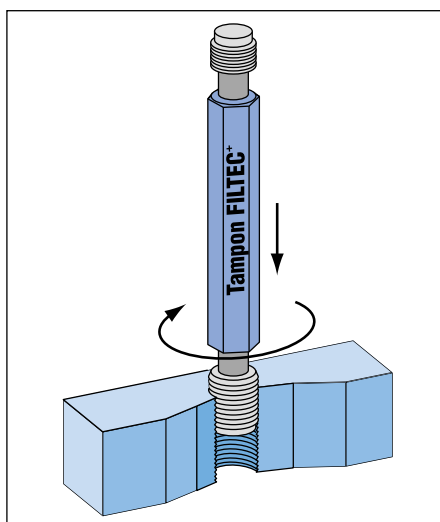

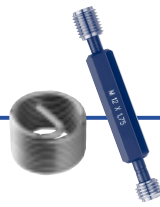
**METRIC
UNC-UNF
BSP-BSW-BSF**
RANGE OF PRODUCT

Standard dimensions are in black : 269 02 40 00 00

Other dimensions : 269 04 60 00 00

METRIC	Control Plug gauges
Ø and nominal pitch	CODE
M 2 x 0,40	269 02 40 00 00
M 2,5 x 0,45	269 02 45 00 00
M 3 x 0,50	269 03 50 00 00
M 3,5 x 0,60	269 04 60 00 00
M 4 x 0,70	269 04 70 00 00
M 5 x 0,80	269 05 80 00 00
M 6 x 1,00	269 06 01 00 00
M 7 x 1,00	269 07 01 00 00
M 8 x 1,00	269 08 01 00 00
M 8 x 1,25	269 08 02 00 00
M 9 x 1,25	269 09 02 00 00
M 10 x 1,00	269 10 01 00 00
M 10 x 1,25	269 10 02 00 00
M 10 x 1,50	269 10 03 00 00
M 11 x 1,50	269 11 03 00 00
M 12 x 1,00	269 12 01 00 00
M 12 x 1,25	269 12 02 00 00
M 12 x 1,50	269 12 03 00 00
M 12 x 1,75	269 12 04 00 00
M 14 x 1,50	269 14 03 00 00
M 14 x 2,00	269 14 05 00 00
M 16 x 1,50	269 16 03 00 00
M 16 x 2,00	269 16 05 00 00
M 18 x 1,50	269 18 03 00 00
M 18 x 2,00	269 18 05 00 00
M 18 x 2,50	269 18 06 00 00
M 20 x 1,50	269 20 03 00 00
M 20 x 2,00	269 20 05 00 00
M 20 x 2,50	269 20 06 00 00
M 22 x 1,50	269 22 03 00 00
M 22 x 2,00	269 22 05 00 00
M 22 x 2,50	269 22 06 00 00
M 24 x 1,50	269 24 03 00 00
M 24 x 2,00	269 24 05 00 00
M 24 x 3,00	269 24 07 00 00
M 26 x 1,50	269 26 03 00 00
M 27 x 1,50	269 27 03 00 00
M 27 x 2,00	269 27 05 00 00
M 27 x 3,00	269 27 07 00 00
M 28 x 1,50	269 28 03 00 00
M 30 x 1,50	269 30 03 00 00
M 30 x 2,00	269 30 05 00 00
M 30 x 3,50	269 30 08 00 00

METRIC	Control Plug gauges
Ø and nominal pitch	CODE
M 32 x 1,50	269 32 03 00 00
M 33 x 2,00	269 33 05 00 00
M 33 x 3,00	269 33 07 00 00
M 33 x 3,50	269 33 08 00 00
M 36 x 1,50	269 36 03 00 00
M 36 x 2,00	269 36 05 00 00
M 36 x 3,00	269 36 07 00 00
M 36 x 4,00	269 36 09 00 00
M 39 x 3,00	269 39 07 00 00
M 39 x 4,00	269 39 09 00 00
M 42 x 3,00	269 42 07 00 00
M 42 x 4,50	269 42 10 00 00

BSP-BSW-BSF	Control Plug gauges
Ø and nominal pitch	CODE
BSP	
1/8-28	270 120 100 00
1/4-19	270 140 150 00
3/8-19	270 140 200 00
1/2-14	270 150 250 00
3/4-14	270 150 350 00
7/8-14	270 150 400 00
BSW	
1/4-20	270 220 100 00
5/16-18	270 220 150 00
3/8-16	270 230 200 00
7/16-14	270 230 250 00
1/2-12	270 240 300 00
9/16-12	270 240 350 00
BSF	
1/4-26	270 320 100 00
5/16-22	270 320 150 00
3/8-20	270 330 200 00
7/16-18	270 330 250 00
1/2-16	270 340 300 00
9/16-16	270 340 350 00
5/8-14	270 340 400 00

UNC - UNF	Control Plug gauges
Ø and nominal pitch	CODE
UNC	
2-56	269 91 21 00 00
4-40	269 91 51 00 00
5-40	269 91 51 50 00
6-32	269 91 71 00 00
8-32	269 91 91 00 00
10-24	269 92 11 00 00
1/4 - 20	269 92 32 00 00
5/16 - 18	269 92 52 00 00
3/8 - 16	269 92 73 00 00
7/16 - 14	269 92 93 00 00
1/2 - 13	269 93 14 00 00
9/16 - 12	269 93 34 00 00
5/8 - 11	269 93 54 00 00
3/4-10	269 93 75 00 00
7/8 - 9	269 93 95 00 00
1"-8	269 94 15 00 00
1"1/8-7	269 94 35 00 00
1"1/4-7	269 94 55 00 00
1"3/8-6	269 94 75 00 00
1"1/2-6	269 94 95 00 00
UNF	
6-40	269 91 61 00 00
8-36	269 91 81 00 00
10-32	269 92 01 00 00
1/4 - 28	269 92 42 00 00
5/16 - 24	269 92 62 00 00
3/8 - 24	269 92 83 00 00
7/16 - 20	269 93 03 00 00
1/2 - 20	269 93 24 00 00
9/16 - 18	269 93 44 00 00
5/8 - 18	269 93 64 00 00
3/4 - 16	269 93 85 00 00
7/8-14	269 94 05 00 00
1"-14	269 95 25 00 00
1"-12	269 94 25 00 00
1"1/8-12	269 94 45 00 00
1"1/4-12	269 94 65 00 00
1"3/8-12	269 94 85 00 00
1"1/2-12	269 95 05 00 00



FILTEC⁺

Manual inserting tools "SINGLE SPINDLE"



A reliable and economical inserting tool for FILTEC⁺ thread inserts.

APPLICATIONS

Tapping repairs : FILTEC⁺ single spindle is used only with FILTEC⁺ thread inserts. This tool with no necked nose enables users to fit FILTEC⁺ thread inserts easily and quickly.



The absence of necked nose prevents you from using it with DIN 8140 range products.

PRODUCT SPECIFICATIONS

- FILTEC⁺ single spindle is made up of two elements :
 - 1 driving spindle with elongated slot
 - 1 depth adjustment collar

FILTEC⁺ single spindle is multi-dimensional. As a consequence, the insertion of several equivalent diameters in metric and UNC- UNF is feasible.

Eg : FILTEC⁺ single spindle n° 4 is used for inserting threads in :
M4 x 0,70 / 8-32 / 8-36 (see table below).

- Single spindles are available from diameter :
 - M3 x 0,50 to M22 x 2,50 in metric
 - 4-40 to 7/8-14 in UNC/UNF



Ø and nominal pitch	Single spindle	CODE
M 3 x 0,50	N° 3	142 030 000 00
M 3,5 x 0,60	N° 3	142 030 000 00
M 4 x 0,70	N° 4	142 040 000 00
M 5 x 0,80	N° 6	142 060 000 00
M 6 x 1,00	N° 7	142 070 000 00
M 7 x 1,00	N° 8	142 080 000 00
M 8 x 1,00	N° 9	142 090 000 00
M 8 x 1,25	N° 9	142 090 000 00
M 9 x 1,25	N° 10	142 100 000 00
M 10 x 1,00	N° 11	142 110 000 00
M 10 x 1,25	N° 11	142 110 000 00
M 10 x 1,50	N° 11	142 110 000 00
M 11 x 1,50	N° 12	142 120 000 00
M 12 x 1,00	N° 13	142 130 000 00
M 12 x 1,25	N° 13	142 130 000 00
M 12 x 1,50	N° 13	142 130 000 00
M 12 x 1,75	N° 12	142 120 000 00
M 14 x 1,50	N° 14	142 140 000 00
M 14 x 2,00	N° 14	142 140 000 00
M 16 x 2,00	N° 15	142 150 000 00
M 18 x 2,00	N° 16	142 160 000 00
M 18 x 2,50	N° 16	142 160 000 00
M 20 x 2,00	N° 17	142 170 000 00
M 20 x 2,50	N° 17	142 170 000 00
M 22 x 2,00	N° 18	142 180 000 00
M 22 x 2,50	N° 17	142 170 000 00

Ø and nominal pitch	Single spindle	CODE
UNC		
4-40	N° 2	142 020 000 00
5-40	N° 3	142 030 000 00
6-32	N° 3	142 030 000 00
8-32	N° 4	142 040 000 00
10-24	N° 5	142 050 000 00
1/4 - 20	N° 7	142 070 000 00
5/16 - 18	N° 8	142 080 000 00
3/8 - 16	N° 10	142 100 000 00
7/16 - 14	N° 12	142 120 000 00
1/2 - 13	N° 13	142 130 000 00
9/16 - 12	N° 14	142 140 000 00
5/8 - 11	N° 15	142 150 000 00
3/4 - 10	N° 16	142 160 000 00
UNF		
6-40	N° 3	142 030 000 00
8-36	N° 4	142 040 000 00
10-32	N° 5	142 050 000 00
1/4-28	N° 7	142 070 000 00
5/16-24	N° 9	142 090 000 00
3/8-24	N° 11	142 110 000 00
7/16-20	N° 12	142 120 000 00
1/2-20	N° 14	142 140 000 00
9/16-18	N° 14	142 140 000 00
5/8-18	N° 15	142 150 000 00
3/4-16	N° 17	142 170 000 00
7/8-14	N° 18	142 180 000 00



FILTEC[®]+

Pneumatic inserting tools "ZT FILTEC⁺"

APPLICATIONS

ZT FILTEC⁺ tools are designed for rational, efficient and fast insertion of thread inserts.

They are essential for large series and recommended for medium ones.



FILTEC DIN 8140 thread inserts can not be placed with the assistance of the ZT FILTEC⁺ tool.

PRODUCT SPECIFICATIONS

Adaptable

You can adapt different spindles **2** on this pneumatic inserting tool **1** according to the thread insert diameter you need to insert. This tool does not have any necked nose.

Reliable

- Automatic process
- Insertion at a constant depth.

Handy

- Sturdy yet lightweight : 0,630 kg
- Delivered in a kit.

Economical

- 3 or 4 times faster than manual insertion.
- Its speed and reliability will greatly reduce your costs.
- Speed: 1300 revolutions per minute

PRODUCT RANGE AVAILABLE

- Metric: from M2 to M22.
- UNC-UNF: from 2-56 to 7/8-14





Break-off tools – Extractors



APPLICATIONS



Extractors and break-off tools are used on all types of thread inserts.

PRODUCT SPECIFICATIONS

Break-off tools

- Enable users to break-off the thread insert tail once fitted
- Necessary for the tail break-off to be clean (break-off must be the result of vertical pressure subsequent to a shock).



Do not use inserting tool to break-off the tail.

- The range features 17 break-off tools numbered from 1 to 17.
 - Each tool can be used to break off the tail of several equivalent diameters in metric and UNC/UNF.
- Eg : Break-off tool n° 7 can be used to break M6 x 1,00, _-20 and _-28.
- They are available:
 - from M2 x 0,40 to M22 x 2,50 in metric
 - from 2-56 to 7/8-14 in UNC/UNF



Manual



Automatic

If the broken tail stays in the hole, check if it will cause no damage within the repaired parts.

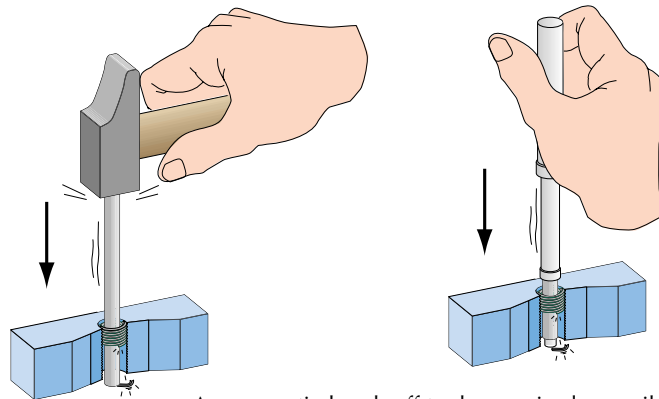

A pneumatic break-off tool range is also available (M3 to M12).
Thus, you do not need to use a hammer anymore.

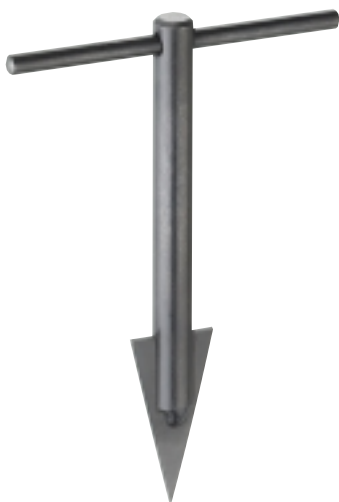

Extractors

- Enable users to extract a thread insert once fitted (if necessary).
- 3 models cover all diameters (n°1-2-3).
- Thanks to its triangular shape, the extractor can be locked into the thread insert. By rotating the tool while keeping a vertical thrust, the thread insert can be unscrewed.

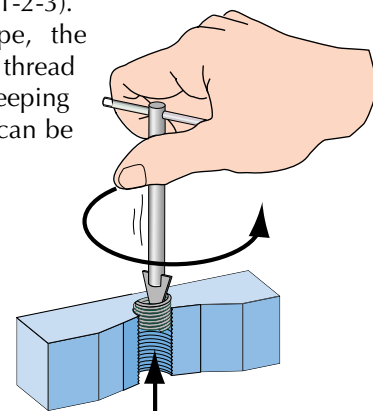

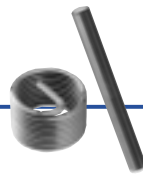

PRODUCT RANGE

 For a specific diameter, the break-off tool can be different according to the kind of thread insert installed (FILTEC⁺ or LOCKFIL⁺) because of the polygonal turns of the LOCKFIL⁺.

**METRIC
UNC-UNF**

Ex: FILTEC⁺ M4 x 0,70 break-off tool N°4
 LOCKFIL⁺ M4 x 0,70 break-off tool N°3

METRIC	Break-off tool FILTEC ⁺ FILTEC		Break-off tool LOCKFIL ⁺ LOCKFIL	
	N°	CODE	N°	CODE
M 2 x 0,40	1	264 010 000 00	-	-
M 2,5 x 0,45	1	264 010 000 00	1	264 010 000 00
M 3 x 0,50	3	264 030 000 00	2	264 020 000 00
M 3,5 x 0,60	3	264 030 000 00	3	264 030 000 00
M 4 x 0,70	4	264 040 000 00	3	264 030 000 00
M 5 x 0,80	6	264 060 000 00	5	264 050 000 00
M 6 x 1,00	7	264 070 000 00	6	264 060 000 00
M 7 x 1,00	8	264 080 000 00	7	264 070 000 00
M 8 x 1,00	9	264 090 000 00	8	264 080 000 00
M 8 x 1,25	9	264 090 000 00	8	264 080 000 00
M 9 x 1,25	10	264 100 000 00	9	264 090 000 00
M 10 x 1,00	11	264 110 000 00	11	264 110 000 00
M 10 x 1,25	11	264 110 000 00	11	264 110 000 00
M 10 x 1,50	11	264 110 000 00	10	264 100 000 00
M 11 x 1,50	12	264 120 000 00	11	264 110 000 00
M 12 x 1,00	13	264 130 000 00	13	264 130 000 00
M 12 x 1,25	13	264 130 000 00	13	264 130 000 00
M 12 x 1,50	13	264 130 000 00	12	264 120 000 00
M 12 x 1,75	12	264 120 000 00	12	264 120 000 00
M 14 x 1,50	14	264 140 000 00	14	264 140 000 00
M 14 x 2,00	14	264 140 000 00	14	264 140 000 00
M 16 x 1,50	15	264 150 000 00	15	264 150 000 00
M 16 x 2,00	15	264 150 000 00	15	264 150 000 00
M 18 x 1,50	16	264 160 000 00	16	264 160 000 00
M 18 x 2,00	16	264 160 000 00	16	264 160 000 00
M 18 x 2,50	15	264 150 000 00	15	264 150 000 00
M 20 x 1,50	17	264 170 000 00	17	264 170 000 00
M 20 x 2,00	17	264 170 000 00	17	264 170 000 00
M 20 x 2,50	16	264 160 000 00	16	264 160 000 00
M 22 x 1,50	17	264 170 000 00	17	264 170 000 00
M 22 x 2,00	17	264 170 000 00	17	264 170 000 00
M 22 x 2,50	17	264 170 000 00	17	264 170 000 00

UNC UNF	Break-off tool FILTEC ⁺ FILTEC		Break-off tool LOCKFIL ⁺ LOCKFIL	
	N°	CODE	N°	CODE
UNC				
2-56	1	264 010 000 00	1	264 010 000 00
4-40	3	264 030 000 00	2	264 020 000 00
5-40	3	264 030 000 00	3	264 030 000 00
6-32	3	264 030 000 00	3	264 030 000 00
8-32	5	264 050 000 00	4	264 040 000 00
10-24	4	264 040 000 00	4	264 040 000 00
1/4 - 20	7	264 070 000 00	7	264 070 000 00
5/16 - 18	8	264 080 000 00	8	264 080 000 00
3/8 - 16	10	264 100 000 00	9	264 090 000 00
7/16 - 14	11	264 110 000 00	11	264 110 000 00
1/2 - 13	13	264 130 000 00	12	264 120 000 00
9/16 - 12	14	264 140 000 00	14	264 140 000 00
5/8 - 11	14	264 140 000 00	14	264 140 000 00
3/4 - 10	16	264 160 000 00	16	264 160 000 00
7/8 - 9	17	264 170 000 00	17	264 170 000 00
UNF				
6-40	3	264 030 000 00	2	264 020 000 00
8-36	4	264 040 000 00	3	264 030 000 00
10-32	5	264 050 000 00	4	264 040 000 00
1/4-28	7	264 070 000 00	7	264 070 000 00
5/16-24	9	264 090 000 00	8	264 080 000 00
3/8-24	11	264 110 000 00	10	264 100 000 00
7/16-20	12	264 120 000 00	11	264 110 000 00
1/2-20	14	264 140 000 00	13	264 130 000 00
9/16-18	14	264 140 000 00	14	264 140 000 00
5/8-18	15	264 150 000 00	15	264 150 000 00
3/4-16	17	264 170 000 00	16	264 160 000 00
7/8-14	17	264 170 000 00	17	264 170 000 00

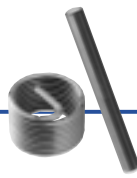

**BSP
BSW-BSF**

BSP BSW	Break-off tool FILTEC ⁺	
Ø and nominal pitch	N°	CODE
BSP		
1/8-28	11	264 110 000 00
1/4-19	14	264 140 000 00
3/8-19	15	264 150 000 00
1/2-14	17	264 170 000 00
5/8-14	17	264 170 000 00
BSW		
1/4-20	7	264 070 000 00
5/16-18	8	264 080 000 00
3/8-16	10	264 100 000 00
7/16-14	11	264 110 000 00
1/2-12	12	264 120 000 00
9/16-12	14	264 140 000 00
5/8-11	14	264 140 000 00
3/4-10	16	264 160 000 00
7/8-9	17	264 170 000 00

BSF	Break-off tool FILTEC ⁺	
Ø and nominal pitch	N°	CODE
BSF		
1/4-26	7	264 070 000 00
5/16-22	9	264 090 000 00
3/8-20	10	264 100 000 00
7/16-18	12	264 120 000 00
1/2-16	13	264 130 000 00
9/16-16	14	264 140 000 00
5/8-14	15	264 150 000 00
3/4-12	16	264 160 000 00
7/8-11	17	264 170 000 00

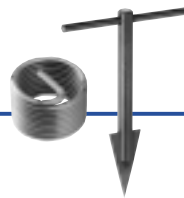
METRIC	 Automatic break-off tool FILTEC ⁺	
Ø	CODE	
2	039 02 000 000	
2,5	039 02 500 000	
3	039 03 000 000	
4	039 04 000 000	
5	039 05 000 000	
6	039 06 000 000	
8	039 08 000 000	
10	039 10 000 000	
12	039 12 000 000	
14	039 14 000 000	
16	039 16 000 000	



METRIC
UNC-UNF
BSP-BSW-BSF

PRODUCT RANGE

For some diameters both extractor n°1 and extractor n° 2 can be used.

Eg: M8 x 1,25 266 10 00 00 00 or
 266 20 00 00 00

METRIC	Extractor
Ø and nominal pitch	CODE
M 2 x 0,40 M 2,5 x 0,45 M 3 x 0,50 M 3,5 x 0,60 M 4 x 0,70 M 5 x 0,80 M 6 x 1,00 M 7 x 1,00	266 10 00 00 00
M 8 x 1,00 M 8 x 1,25 M 9 x 1,25 M 10 x 1,00 M 10 x 1,25 M 10 x 1,50 M 11 x 1,50 M 12 x 1,00 M 12 x 1,25 M 12 x 1,50 M 12 x 1,75	266 10 00 00 00 or 266 20 00 00 00
M 14 x 1,50 M 14 x 2,00 M 16 x 1,50 M 16 x 2,00 M 18 x 1,50 M 18 x 2,00 M 18 x 2,50 M 20 x 1,50 M 20 x 2,00 M 20 x 2,50 M 22 x 1,50 M 22 x 2,00 M 22 x 2,50	266 20 00 00 00
M 24 x 1,50 M 24 x 2,00 M 24 x 3,00	266 30 00 00 00

UNC UNF	Extractor
Ø and nominal pitch	CODE
UNC 2-56 4-40 5-40 6-32 8-32 10-24 1/4 - 20	266 100 000 00
5/16 - 18 3/8 - 16 7/16 - 24	266 100 000 00 or 266 200 000 00
1/2 - 13 9/16 - 12 5/8 - 11 3/4 - 10 7/8 - 9	266 200 000 00
1" - 8 1" 1/8-7	266 300 000 00
UNF 6-40 8-36 10-32 1/4-28	266 100 000 00
5/16-24 3/8-24 7/16-20	266 100 000 00 or 266 200 000 00
1/2-20 9/16-18 5/8-18 3/4-16 7/8-14	266 200 000 00
1" - 14 1" - 12 1" 1/8-12	266 300 000 00

BSP BSW BSF	Extractor
Ø and nominal pitch	CODE
BSP 1/8-28 1/4-19 3/8-19 1/2-14	266 200 000 00
5/8-14 3/4-14 7/8-14 1"-11	266 300 000 00
BSW 1/4-20 5/16-18	266 100 000 00 or 266 200 000 00
3/8-16 7/16-14 1/2-12 9/16-12 5/8-11 3/4-10 7/8-9	266 200 000 00
1"-8	266 300 000 00
BSF 1/4-26 5/16-22	266 100 000 00 or 266 200 000 00
3/8-20 7/16-18 1/2-16 9/16-16 5/8-14 3/4-12 7/8-11	266 200 000 00
1"-10	266 300 000 00



FILTEC[®]+

Blisters and Monokits



A range of tool kits for FILTEC⁺ thread inserts.

PRODUCT SPECIFICATIONS

Each Monokit tool kit is designed for a specific diameter and pitch and just the packaging presentation differs. The application field remains the same.

Tool kit contents :

Blister FILTEC⁺ : *Transparent blister packaging allowing visualisation of the product*

- 1 thread insert tap
- 1 inserting tool for selected diameter (up to M14)
- 10 thread inserts length 1,5 d from M3 to M10 or 5 thread inserts length 1,5 d from M11 to M14
- 1 break-off tool up to M12



Blister FILTEC⁺

Monokit FILTEC⁺ : *Closed case. Product is not visible. The case can be easily stored after use*

Up to M14 (small box P3) :

- 1 thread insert tap
- 1 inserting tool for selected diameter
- 10 thread inserts length 1,5 d from M3 to M10 or 5 thread inserts length 1,5 d from M11 to M14
- 1 break-off tool up to M12

From M16 to M22 (large box P5) :

- 1 thread insert tap
- 1 inserting tool for selected diameter
- 5 thread inserts length 1,5 d











Monokit FILTEC⁺
(Kit P3)



METRIC
UNC-UNF

PRODUCT RANGE

	 	 		 	 	
Ø and nominal pitch	CODE	CODE	Ø and nominal pitch	CODE	CODE	
M 3 x 0,50	257 03 50 00 00	256 03 50 00 00	UNC	4-40	259 151 000 00	258 151 000 00
M 3,5 x 0,60	257 04 60 00 00	256 04 60 00 00		5-40	259 141 000 00	258 141 000 00
M 4 x 0,70	257 04 70 00 00	256 04 70 00 00		6-32	259 171 000 00	258 171 000 00
M 5 x 0,80	257 05 80 00 00	256 05 80 00 00		8-32	259 191 000 00	258 191 000 00
M 6 x 1,00	257 06 01 00 00	256 06 01 00 00		10-24	259 211 000 00	258 211 000 00
M 7 x 1,00	257 07 01 00 00	256 07 01 00 00		1/4-20	259 232 000 00	258 232 000 00
M 8 x 1,00	257 08 01 00 00	256 08 01 00 00		5/16-18	259 252 000 00	258 252 000 00
M 8 x 1,25	257 08 02 00 00	256 08 02 00 00		3/8-16	259 273 000 00	258 273 000 00
M 9 x 1,25	257 09 02 00 00	256 09 02 00 00		7/16-14	259 293 000 00	258 293 000 00
M 10 x 1,00	257 10 01 00 00	256 10 01 00 00		1/2-13	259 314 000 00	258 314 000 00
M 10 x 1,25	257 10 02 00 00	256 10 02 00 00	9/16-12	-	258 334 000 00	
M 10 x 1,50	257 10 03 00 00	256 10 03 00 00	5/8-11	-	258 354 000 00	
M 11 x 1,50	257 11 03 00 00	256 11 03 00 00	3/4-10	-	258 379 000 00	
M 12 x 1,00	257 12 01 00 00	256 12 01 00 00	UNF	6-40	259 161 000 00	258 161 000 00
M 12 x 1,25	257 12 02 00 00	256 12 02 00 00		8-36	259 181 000 00	258 181 000 00
M 12 x 1,50	257 12 03 00 00	256 12 03 00 00		10-32	259 201 000 00	258 201 000 00
M 12 x 1,75	257 12 04 00 00	256 12 04 00 00		1/4-28	259 242 000 00	258 242 000 00
M 14 x 1,50	257 14 03 00 00	256 14 03 00 00		5/16-24	259 262 000 00	258 262 000 00
M 14 x 2,00	257 14 05 00 00	256 14 05 00 00		3/8-24	259 283 000 00	258 283 000 00
M 16 x 2,00	-	256 16 05 00 00		7/16-20	259 303 000 00	258 303 000 00
M 18 x 2,50	-	256 18 06 00 00		1/2-20	259 324 000 00	258 324 000 00
M 20 x 2,50	-	256 20 06 00 00		9/16-18	259 344 000 00	258 344 000 00
M 22 x 2,50	-	256 22 06 00 00		5/8-18	-	258 364 000 00
			3/4-16	-	258 389 000 00	



FILTEC[®]+

Monokit Assortment Kits



A range of assortment kits for FILTEC⁺ thread inserts.

APPLICATIONS

These kits are essential for maintenance departments in factories, garages, workshops etc.

They are designed for repairing and restoring initial dimensions to all the tappings that have been damaged, improperly threaded etc.

They provide the necessary equipment to repair most common dimensions.

PRODUCT SPECIFICATIONS

With each assortment kit, you will be able to use several diameters of FILTEC⁺ thread inserts.



Kit N°	Ø and nominal pitch	CODE	CONTENT
10	M 4 x 0,70 M 5 x 0,80 M 6 x 1,00 M 8 x 1,25 M 10 x 1,50 M 12 x 1,75	254 10 00 00 00	<ul style="list-style-type: none"> • 1 single spindle inserting tool per diameter • 10 FILTEC⁺ 4 x 70 AC 6 • 10 FILTEC⁺ 5 x 80 AC 7,5 • 10 FILTEC⁺ 6 x 100 AC 9 • 10 FILTEC⁺ 8 x 125 AC 12 • 10 FILTEC⁺ 10 x 150 AC 15 • 10 FILTEC⁺ 12 x 175 AC 12 • 1 thread insert tap per diameter • 1 break-off tool per diameter
40 6 dimensions to choose to make up a kit at your convenience :	4 x 70 5 x 80 6 x 100 7 x 100 4-40 1/12-13 8 x 100 6-32 6-40 8 x 125 8-32 10-32 8 x 125 10-24 10 x 100 1/4-20 1/4-28 10 x 125 5/16-18 5/16-24 10 x 150 3/8-16 3/8-24 12 x 100 7/16-14 7/16-20 12 x 125 12 x 150 12 x 175	254 40 00 00 00	<ul style="list-style-type: none"> • 1 inserting tool "single spindle" per diameter • 10 FILTEC⁺ thread inserts per diameter • 1 thread insert tap per diameter • 1 break-off tool per diameter



FILTEC[®] DIN 8140

*This product range of thread insert is the only one to comply with DIN 8140. Inserting tools with a necked nose. The other tools and the insertion steps remain the same as for the **FILTEC⁺** product range.*

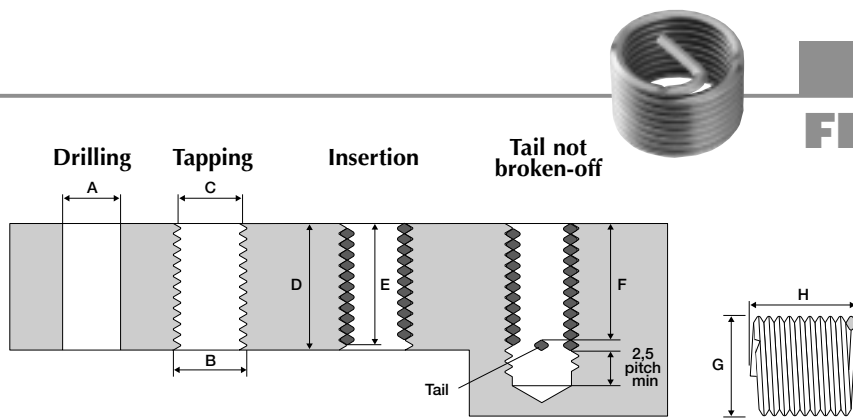

**METRIC
DIN 8140**

Ø and nominal pitch	x d	D : base tapping length	CODE 100 : Filtec 110 : Lockfil	H : nb. of turns at the initial state Tol. -0,25	G : Ø initial state min - max	A : Drilling		Tapping	
						Ø drill	Tolerance min max	B : Ø ext. min	C : Ø outer
M 2 x 0,40	1 d	2,00	100 02 40 02 00	2,9	2,60 2,80	2,10	2,090 + 0,090	2,520	2,260 + 0,053
	1,5 d	3,00	100 02 40 03 00	4,9					
	2 d	4,00	100 02 40 04 00	6,9					
	2,5 d	5,00	100 02 40 05 00	8,9					
M 2,5 x 0,45	1 d	2,50	100 02 45 25 00	3,5	3,30 3,50	2,60	2,597 + 0,100	3,084	2,792 + 0,055
	1,5 d	3,75	100 02 45 37 50	5,9					
	2 d	5,00	100 02 45 50 00	8,1					
	2,5 d	6,25	100 02 45 62 50	10,5					
M 3 x 0,50	1 d	3,00	100 03 50 03 00	3,9	3,80 4,00	3,20	3,108 + 0,112	3,650	3,325 + 0,059
	1,5 d	4,50	100 03 50 04 50	6,3					
	2 d	6,00	100 03 50 06 00	8,7					
	2,5 d	7,50	100 03 50 07 50	11,1					
M 4 x 0,70	1 d	4,00	100 04 70 04 00	3,7	5,15 5,35	4,20	4,152 + 0,140	4,910	4,455 + 0,074
	1,5 d	6,00	100 04 70 06 00	6,1					
	2 d	8,00	100 04 70 08 00	8,4					
	2,5 d	10,00	100 04 70 10 00	10,9					
M 5 x 0,80	1 d	5,00	100 05 80 05 00	4,3	6,35 6,60	5,20	5,174 + 0,160	6,040	5,520 + 0,077
	1,5 d	7,50	100 05 80 07 50	6,9					
	2 d	10,00	100 05 80 10 00	9,7					
	2,5 d	12,50	100 05 80 12 50	12,3					
M 6 x 1,00	1 d	6,00	100 06 01 06 00	4,2	7,60 7,85	6,30	6,217 + 0,190	7,300	6,650 + 0,092
	1,5 d	9,00	100 06 01 09 00	6,9					
	2 d	12,00	100 06 01 12 00	9,6					
	2,5 d	15,00	100 06 01 15 00	12,3					
M 7 x 1,00	1 d	7,00	100 07 01 07 00	5,3	8,65 8,90	7,30	7,217 + 0,190	8,300	7,650 + 0,092
	1,5 d	10,50	100 07 01 10 50	8,2					
	2 d	14,00	100 07 01 14 00	11,1					
	2,5 d	17,50	100 07 01 17 50	14,3					
M 8 x 1,00	1 d	8,00	100 08 01 08 00	6,1	9,85 10,10	8,30	8,217 + 0,190	9,300	8,650 + 0,092
	1,5 d	12,00	100 08 01 12 00	9,5					
	2 d	16,00	100 08 01 16 00	12,9					
	2,5 d	20,00	100 08 01 20 00	16,5					
M 8 x 1,25	1 d	8,00	100 08 02 08 00	4,7	9,85 10,10	8,40	8,271 + 0,212	9,624	8,812 + 0,099
	1,5 d	12,00	100 08 02 12 00	7,4					
	2 d	16,00	100 08 02 16 00	10,6					
	2,5 d	20,00	100 08 02 20 00	13,5					
M 10 x 1,00	1 d	10,00	100 10 01 10 00	7,6	12,10 12,50	10,30	10,217 + 0,190	11,300	10,650 + 0,092
	1,5 d	15,00	100 10 01 15 00	12,1					
	2 d	20,00	100 10 01 20 00	16,3					
	2,5 d	25,00	100 10 01 25 00	20,7					

FILTEC®

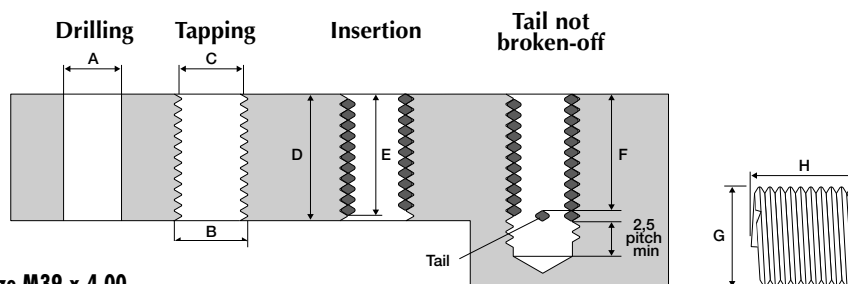
**METRIC
DIN 8140**

Sizes > M16 do not appear in the catalogue.

Feel free to contact us for any request up to size M39 x 4,00.

Ø and nominal pitch	x d	D : base tapping length	CODE 100 : Filtec 110 : Lockfil	H : nb. of turns at the initial state Tol. -0,25	G : Ø initial state min - max	A : Drilling		Tapping	
						Ø drill	Tolerance min max	B : Ø ext. min	C : Ø outer
M 10 x 1,25	1 d	10,00	100 10 02 10 00	6,0	12,10 12,50	10,40	10,271 + 0,212	11,624	10,812 + 0,099
	1,5 d	15,00	100 10 02 15 00	9,7					
	2 d	20,00	100 10 02 20 00	13,1					
M 10 x 1,50	1 d	10,00	100 10 03 10 00	5,0	12,10 12,50	10,50	10,324 + 0,236	11,948	10,974 + 0,115
	1,5 d	15,00	100 10 03 15 00	8,1					
	2 d	20,00	100 10 03 20 00	11,2					
	2,5 d	25,00	100 10 03 25 00	14,2					
M 12 x 1,00	1 d	12,00	100 12 01 12 00	9,3	14,40 14,80	12,30	12,217 + 0,190	13,300	12,650 + 0,100
	1,5 d	18,00	100 12 01 18 00	14,5					
	2 d	24,00	100 12 01 24 00	19,5					
M 12 x 1,25	1 d	12,00	100 12 02 12 00	7,4	14,40 14,80	12,40	12,271 + 0,212	13,624	12,812 + 0,114
	1,5 d	18,00	100 12 02 18 00	11,6					
	2 d	24,00	100 12 02 24 00	15,9					
M 12 x 1,50	1 d	12,00	100 12 03 12 00	6,2	14,40 14,80	12,50	12,324 + 0,236	13,948	12,974 + 0,125
	1,5 d	18,00	100 12 03 18 00	9,8					
	2 d	24,00	100 12 03 24 00	13,5					
	2,5 d	30,00	100 12 03 30 00	15,7					
M 12 x 1,75	1 d	12,00	100 12 04 12 00	5,2	14,40 14,80	12,50	12,379 + 0,265	14,274	13,137 + 0,134
	1,5 d	18,00	100 12 04 18 00	8,4					
	2 d	24,00	100 12 04 24 00	11,7					
	2,5 d	30,00	100 12 04 30 00	14,7					
M 14 x 1,50	1 d	14,00	100 14 03 14 00	7,25	16,80 17,20	14,50	14,324 + 0,236	15,948	14,974 + 0,125
	1,5 d	21,00	100 14 03 21 00	11,45					
	2 d	28,00	100 14 03 28 00	15,65					
	2,5 d	35,00	100 14 03 35 00	19,45					
M 14 x 2,00	1 d	14,00	100 14 05 14 00	5,6	16,80 17,20	14,50	14,433 + 0,300	16,598	15,299 + 0,145
	1,5 d	21,00	100 14 05 21 00	8,8					
	2 d	28,00	100 14 05 28 00	12,0					
	2,5 d	35,00	100 14 05 35 00	15,2					
M 16 x 1,50	1 d	16,00	100 16 03 16 00	8,7	19,00 19,40	16,50	16,324 + 0,236	17,948	16,974 + 0,125
	1,5 d	24,00	100 16 03 24 00	13,4					
	2 d	32,00	100 16 03 32 00	18,1					
	2,5 d	40,00	100 16 03 40 00	22,9					
M 16 x 2,00	1 d	16,00	100 16 05 16 00	6,5	19,00 19,40	16,50	16,433 + 0,300	18,598	17,299 + 0,145
	1,5 d	24,00	100 16 05 24 00	10,1					
	2 d	32,00	100 16 05 32 00	13,8					
	2,5 d	40,00	100 16 05 40 00	17,5					



FILTEC®

Manual inserting tools



A range of inserting tools for FILTEC thread inserts.

APPLICATIONS

FILTEC inserting tools are designed for manual insertion of FILTEC thread inserts (repairs and small series).



They are used for all types of thread inserts.

PRODUCT SPECIFICATIONS

Multi-dimensional inserting tools

FILTEC inserting tools are multi-dimensional up to diameter 16.

Multi-dimensional tools are made up of two elements :

- 1 **1 inserting tool without unit** (standard crank-handle and standard body) on which a unit is adapted.
- 2 **1 unit** (drive spindle and necked nose) delivered to diameter and pitch of FILTEC threads to be fitted.

An inserting tool, without unit, can be used with several units of different diameters (see table below).

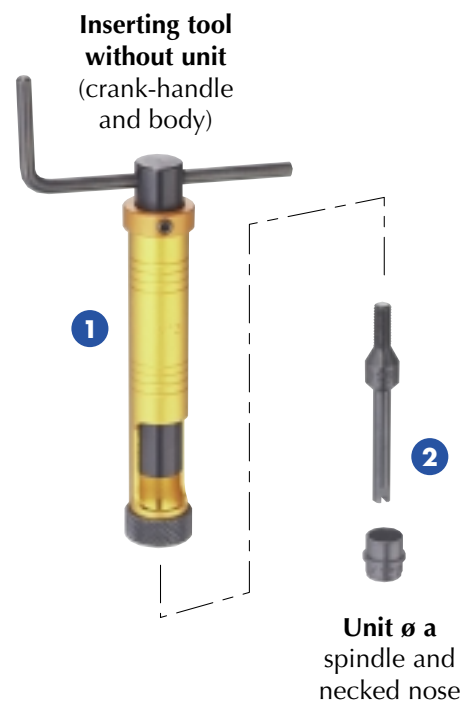

METRIC DIN 8140

N°	Ø and nominal pitch	Dimensions			CODE	CODE	CODE
		A	B	C			
	* threaded spindle				 Complete tool	 Unit (Spindle + necked nose)	 Inserting tool without unit (crank-handle and body)
1	M 2 x 0,40* M 2,5 x 0,45* M 3 x 0,50* M 4 x 0,70 M 5 x 0,80	70	12	141	150 02 40 00 00 150 02 45 00 00 150 03 50 00 00 150 04 70 00 00 150 05 80 00 00	155 02 40 00 00 155 02 45 00 00 155 03 50 00 00 155 04 70 00 00 155 05 80 00 00	161 100 000 00
2	M 6 x 1,00 M 8 x 1,25	70	16	160	150 06 01 00 00 150 08 02 00 00	155 06 01 00 00 155 08 02 00 00	161 200 000 00
3	M 10 x 1,50 M 12 x 1,75	90	20	179	150 10 03 00 00 150 12 04 00 00	155 10 03 00 00 155 12 04 00 00	161 300 000 00
4	M 14 x 1,50 M 14 x 2,00 M 16 x 1,50 M 16 x 2,00	90	25	199	150 14 03 00 00 150 14 05 00 00 150 16 03 00 00 150 16 05 00 00	155 14 03 00 00 155 14 05 00 00 155 16 03 00 00 155 16 05 00 00	161 400 000 00

Some sizes do not appear in the catalogue. Please, feel free to contact us for any other request.



FILTEC®

Repair tool kit

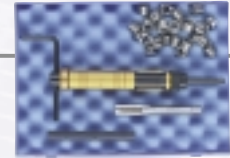

A complete range of repair kits for fitting FILTEC thread inserts.

APPLICATIONS

Repair kits provide all necessary tools to thread tapping or to quickly and economically repair them in a given diameter and pitch.

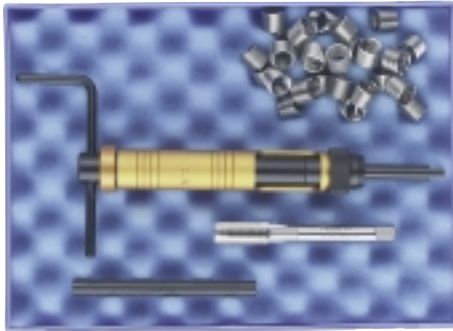

PRODUCT SPECIFICATIONS

Repair tool kits are made for 1 diameter and 1 pitch.

Box content :

- 1 thread insert tap
- 1 inserting tool with a necked nose mounted in selected diameter, which can be adapted to adjacent dimensions (see tables).
- 25 thread inserts length 1,5 d or 10 thread inserts length 1 d (it depends on the kit)
- 1 break-off tool up to diameter 16

METRIC
DIN 8140

N°	Ø and nominal pitch	CODE	CONTENT
1	M 2 x 0,40 M 2,5 x 0,45 M 3 x 0,50 M 4 x 0,70 M 5 x 0,80	260 02 40 00 00 260 02 45 00 00 260 03 50 00 00 260 04 70 00 00 260 05 80 00 00	<ul style="list-style-type: none"> • 1 thread insert tap • 1 inserting tool n° 1 mounted in selected Ø which can be adapted from Ø 2,5 to Ø 5 • 25 thread inserts length 1,5 d • 1 break-off tool
2	M 6 x 1,00 M 8 x 1,25	260 06 01 00 00 260 08 02 00 00	<ul style="list-style-type: none"> • 1 thread insert tap • 1 inserting tool n° 2 mounted in selected Ø which can be adapted from Ø 6 to Ø 8 • 25 thread inserts length 1,5 d • 1 break-off tool
3	M 10 x 1,50	260 10 03 00 00	<ul style="list-style-type: none"> • 1 thread insert tap • 1 inserting tool n° 3 mounted in selected Ø which can be adapted from Ø 10 to Ø 12 • 25 thread inserts length 1,5 d • 1 break-off tool
	M 12 x 1,75	260 12 04 00 00	<ul style="list-style-type: none"> • 1 thread insert tap • 1 inserting tool n° 3 mounted in selected Ø which can be adapted from Ø 10 to Ø 12 • 10 thread inserts length 1d • 1 break-off tool
4	M 14 x 1,50 M 14 x 2,00 M 16 x 1,50 M 16 x 2,00	260 14 03 00 00 260 14 05 00 00 260 16 03 00 00 260 16 05 00 00	<ul style="list-style-type: none"> • 1 thread insert tap • 1 inserting tool n° 4 mounted in selected Ø which can be adapted from Ø 14 to Ø 16 • 10 thread inserts length 1d • 1 break-off tool



FILTEC®

Assortment kits



A complete range of assortment kits for FILTEC thread inserts.

APPLICATIONS

These kits are essential for maintenance teams in factories, garages, workshops, etc.

They are designed for repairing and restoring initial dimensions to all the tappings that have been damaged, improperly threaded, etc.

PRODUIT SPECIFICATIONS

With each assortment kit, you will be able to use several diameters of FILTEC thread inserts.



METRIC DIN 8140

Kit N°	Ø and nominal pitch	CODE	CONTENT
1	M 2,5 x 0,45 M 3 x 0,50 M 4 x 0,70 M 5 x 0,80	250 10 00 00 00	<ul style="list-style-type: none"> • 1 inserting tool n° 1 which can be adapted from Ø 2,5 to Ø 5 • 20 FILTEC 2,5 x 45 AC 3,75 • 20 FILTEC 3 x 50 AC 4,5 • 20 FILTEC 4 x 70 AC 6 • 20 FILTEC 5 x 80 AC 7,5 • 1 thread insert tap, 1 necked nose, 1 spindle and 1 break-off tool per Ø
5	M 5 x 0,80 M 6 x 1,00 M 8 x 1,25 M 10 x 1,50 M 12 x 1,75	250 50 00 00 00	<ul style="list-style-type: none"> • 1 inserting tool n° 2 which can be adapted from Ø 6 to Ø 9 • 1 inserting tool n° 3 which can be adapted from Ø 10 to Ø 12 • 10 FILTEC 5 x 80 AC 7,5 • 10 FILTEC 6 x 100 AC 9 • 10 FILTEC 8 x 125 AC 12 • 10 FILTEC 10 x 150 AC 15 • 10 FILTEC 12 x 175 AC 12 • 1 thread insert tap, 1 necked nose, 1 spindle and 1 break-off tool per Ø
6	M 6 x 1,00 M 7 x 1,00 M 8 x 1,25 M 10 x 1,50 M 12 x 1,75	250 60 00 00 00	<ul style="list-style-type: none"> • 1 inserting tool n° 2 which can be adapted from Ø 6 to Ø 9 • 1 inserting tool n° 3 which can be adapted from Ø 10 to Ø 12 • 10 FILTEC 6 x 100 AC 9 • 10 FILTEC 7 x 100 AC 10,5 • 10 FILTEC 8 x 125 AC 12 • 10 FILTEC 10 x 150 AC 15 • 10 FILTEC 12 x 175 AC 12 • 1 thread insert tap, 1 necked nose, 1 spindle and 1 break-off tool per Ø

FILTEC Refill boxes

Each kit can be restocked with boxes containing similar quantities and dimensions as found in the assortment kits.

Restock FILTEC N° 1 **250 11 00 00 00**

Restock FILTEC N° 5 **250 51 00 00 00**

Restock FILTEC N° 6 **250 61 00 00 00**

